

Flow in pipes

Consider the flow of an incompressible viscous fluid in a full pipe. In the preceding chapter efforts were made analytically to find the relationship between the velocity, pressure, etc., for this case. In this chapter, however, from a more practical and materialistic standpoint, a method of expressing the loss using an average flow velocity is stated. By extending this approach, studies will be made on how to express losses caused by a change in the cross-sectional area of a pipe, a pipe bend and a valve, in addition to the frictional loss of a pipe.



Lead city water pipe (Roman remains, Bath, England)

Sending water by pipe has a long history. Since the time of the Roman Empire (about 1BC) lead pipes and clay pipes have been used for the water supply system in cities.

7.1 Flow in the inlet region

Consider a case where fluid runs from a tank into a pipe whose entrance section is fully rounded. At the entrance, the velocity distribution is roughly uniform while the pressure head is lower by $v^2/2g$ (v : average flow velocity).

Since the velocity of a viscous fluid is zero on the wall, the fluid near the wall is decelerated. The range subject to deceleration extends as the fluid flows further downstream, until at last the boundary layers develop up to the pipe centre. For this situation, shown in Fig. 7.1, the section from the entrance to just where the boundary layer develops to the tube centre is called the inlet or entrance region, whose length is called the inlet or entrance length. For the value of L , there are the following equations:

Laminar flow:

$$L = 0.065Red \quad \left\{ \begin{array}{l} \text{computation by Boussinesq} \\ \text{experiment by Nikuradse} \end{array} \right.$$

$$L = 0.06Red \quad \text{computation by Asao, Iwanami and Mori}$$

Turbulent flow:

$$L = 0.693Re^{1/4}d \quad \text{computation by Latzko}$$

$$L = (25 \sim 40)d \quad \text{experiment by Nikuradse}$$

Downstream of the inlet region, the static pressure of the pipe line as measured by the liquid column gauge set in the pipe line turns out, as shown in Fig. 7.1, to be lower by H than the water level of the tank, where

$$H = \lambda \frac{l}{d} \frac{v^2}{2g} + \xi \frac{v^2}{2g} \quad (7.1)$$

$\lambda(l/d)(v^2/2g)$ expresses the frictional loss of head (the lost energy of fluid per unit weight). $\xi(v^2/2g)$ expresses the pressure reduction equivalent to the sum of the velocity stored when the velocity distribution is fully developed plus the additional frictional energy loss above that in fully developed flow consumed during the change in velocity distribution.

The velocity energy of the fluid which has attained the fully developed velocity distribution when $x = L$ is

$$E = \int_0^{d/2} 2\pi r u \frac{\rho u^2}{2} dr \quad (7.2)$$

E is calculated by substituting the equations for the velocity distribution for laminar flow (6.32) into u of this equation. The velocity energy for the same flow at the average velocity is

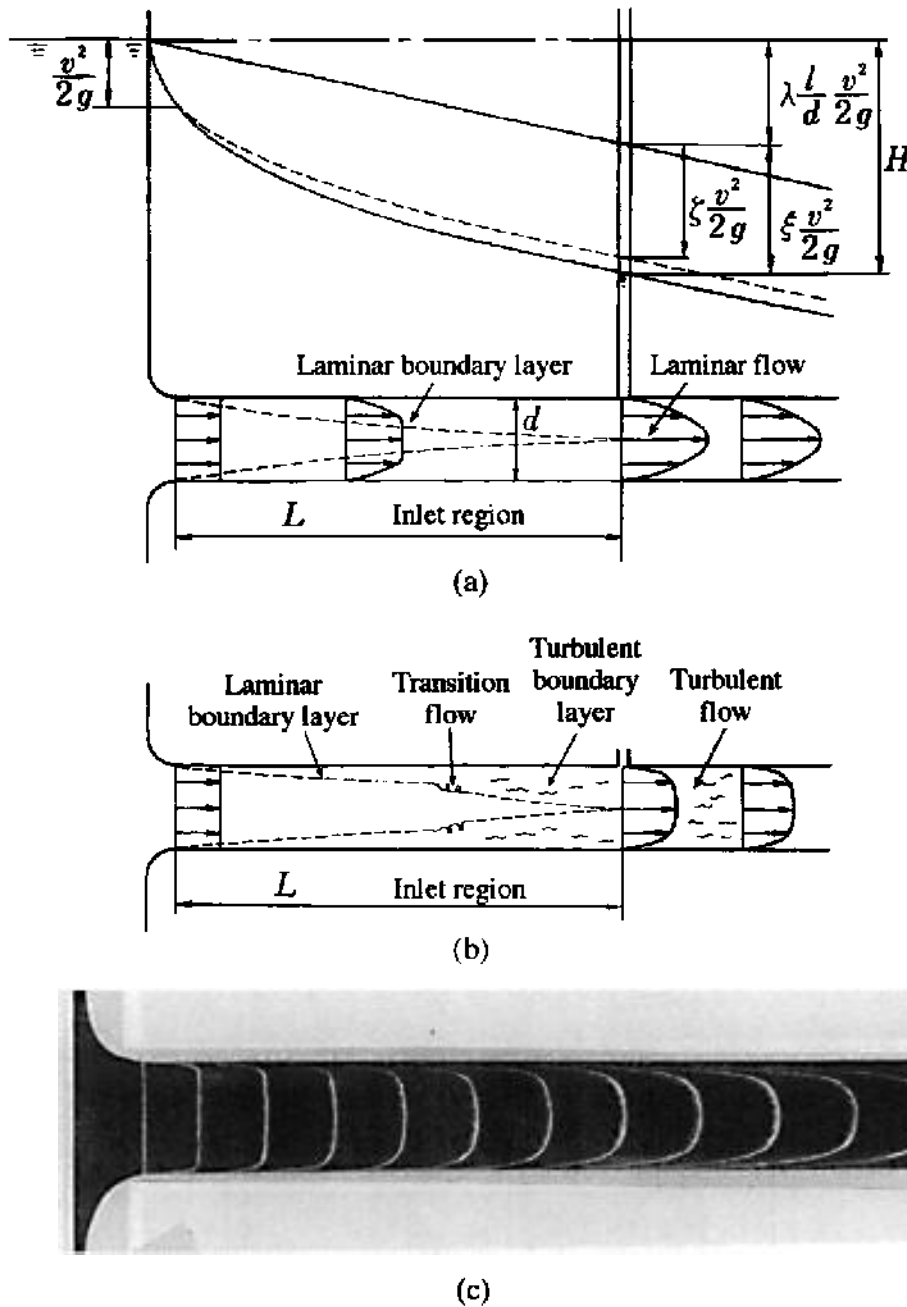

Fig. 7.1 Flow in a circular pipe: (a) laminar flow; (b) turbulent flow; (c) laminar flow (flow visualisation using hydrogen bubble method)

$$E' = \frac{\pi d^2}{4} v \frac{\rho v^2}{2}$$

Putting $E/E' = \zeta$ gives $\zeta = 2$. For the case of turbulent flow, ζ is found to be 1.09 through experiment. ζ is known as the kinetic energy correction factor.

The velocity head equivalent to this energy is

$$\frac{E}{\frac{1}{4} \pi d^2 v \rho g} = \zeta \frac{v^2}{2g} \quad (7.3)$$

This means that, to compensate for this increase in velocity head when the entrance length reaches L , the pressure head must decrease by the same

amount. Furthermore, with the extra energy loss due to the changing velocity distribution included, the value of ξ turns out to be much larger than ζ . $\xi(v^2/2g)$ expresses how much further the pressure would fall than for frictional loss in the inlet region of the pipe if a constant velocity distribution existed. With respect to the value of ξ , for laminar flow values of $\xi = 2.24$ (computation by Boussinesq), 2.16 (computation by Schiller), 2.7 (experiment by Hagen) and 2.36 (experiment by Nakayama and Endo) were reported, while for turbulent flow $\xi = 1.4$ (experiment by Hagen on a trumpet-like tube without an entrance).

7.2 Loss by pipe friction

Let us study the flow in the region where the velocity distribution is fully developed after passing through the inlet region (Fig. 7.2). If a fluid is flowing in the round pipe of diameter d at the average flow velocity v , let the pressures at two points distance l apart be p_1 and p_2 respectively. The relationship between the velocity v and the loss head $h = (p_1 - p_2)/\rho g$ is illustrated in Fig. 7.3, where, for the laminar flow, the loss head h is proportional to the flow velocity v as can clearly be seen from eqn (6.37). For the turbulent flow, it turns out to be proportional to $v^{1.75-2}$.

The loss head is expressed by the following equation as shown in eqn (7.1):

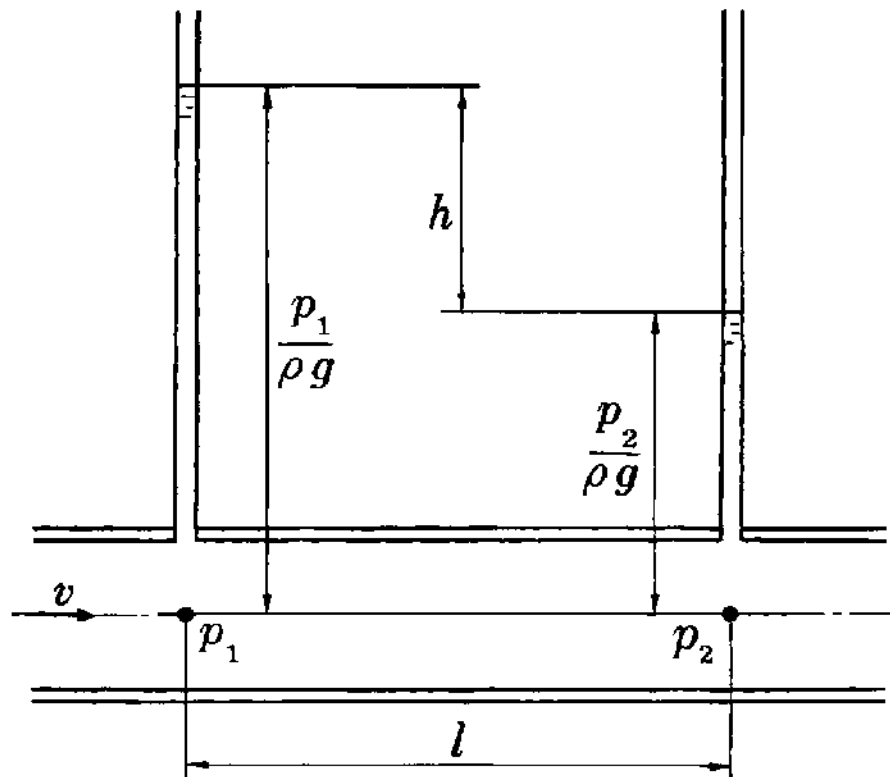

Fig. 7.2 Pipe frictional loss

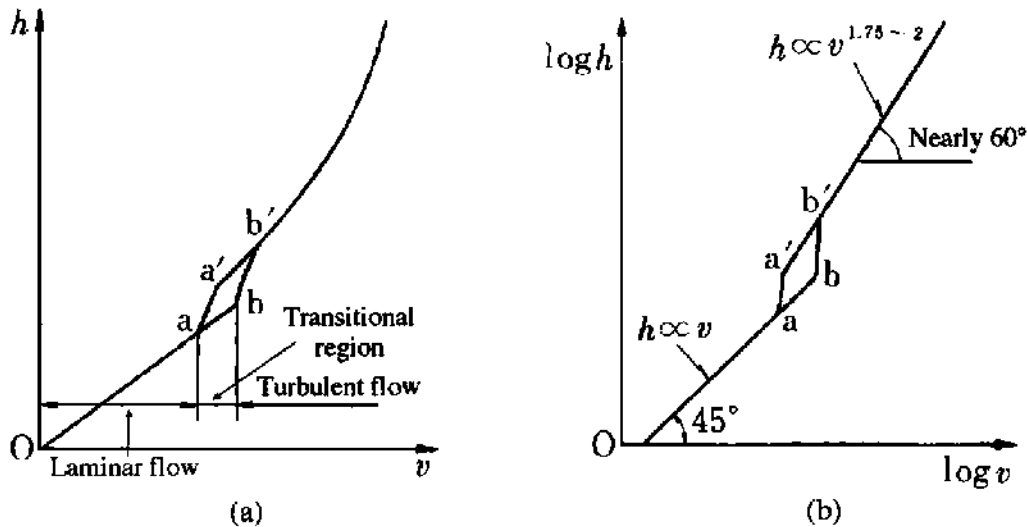

Fig. 7.3 Relationship between flow velocity and loss head

$$h = \lambda \frac{l v^2}{d 2g} \quad (7.4)$$

This equation is called the Darcy–Weisbach equation¹, and the coefficient λ is called the friction coefficient of the pipe.

7.2.1 Laminar flow

In this case, from eqns (6.37) and (7.4),

$$\lambda = 64 \frac{\mu}{\rho v d} = \frac{64}{Re} \quad (7.5)$$

No effect of wall roughness is seen. The reason is probably that the flow turbulence caused by the wall face coarseness is limited to a region near the wall face because the velocity and therefore inertia are small, while viscous effects are large in such a laminar region.

7.2.2 Turbulent flow

λ generally varies according to Reynolds number and the pipe wall roughness.

Smooth circular pipe

The roughness is inside the viscous sublayer if the height ε of wall face ruggedness is

$$\varepsilon \leq 5\nu/v \quad (\text{fluid dynamically smooth}) \quad (7.6)$$

¹ In place of λ , many British texts use $4f$ in this equation. Since friction factor $f = \lambda/4$, it is essential to check the definition to which a value of friction factor refers. The symbol used is not a reliable guide.

From eqn (6.45) and Fig. 6.15, no effect of roughness is seen and λ varies according to Reynolds number only; thus the pipe can be regarded as a smooth pipe.

In the case of a smooth pipe, the following equations have been developed:

equation of Blasius: $\lambda = 0.3164Re^{-1/4}$ ($Re = 3 \times 10^3 \sim 1 \times 10^5$) (7.7)

equation of Nikuradse:

$$\lambda = 0.0032 + 0.221Re^{-0.237}$$
 ($Re = 10^5 \sim 3 \times 10^6$) (7.8)

equation of Kármán–Nikuradse:

$$\lambda = 1/[2\log_{10}(Re\sqrt{\lambda}) - 0.8]^2$$
 ($Re = 3 \times 10^3 \sim 3 \times 10^6$) (7.9)

equation of Itaya:² $\lambda = \frac{0.314}{0.7 - 1.65 \log_{10}(Re) + (\log_{10} Re)^2}$ (7.10)

By combining eqn (7.4) with (7.7), the relationship $h = cv^{1.75}$ (here c is a constant) arises giving the relationship for turbulent flow in Fig. 7.3.

Rough circular pipe

From eqn (6.51) and Fig. 6.15, where

$$\epsilon \geq 70v/v_*$$
 (fully coarse) (7.11)

the wall face roughness extends into the turbulent flow region. This defines the rough pipe case where λ is determined by the roughness only, and is not related to Reynolds number value.

To simulate regular roughness, Nikuradse performed an experiment in 1933 by lacquer-pasting screened sand grains of uniform diameter onto the inner wall of a tube, and obtained the result shown in Fig. 7.4.

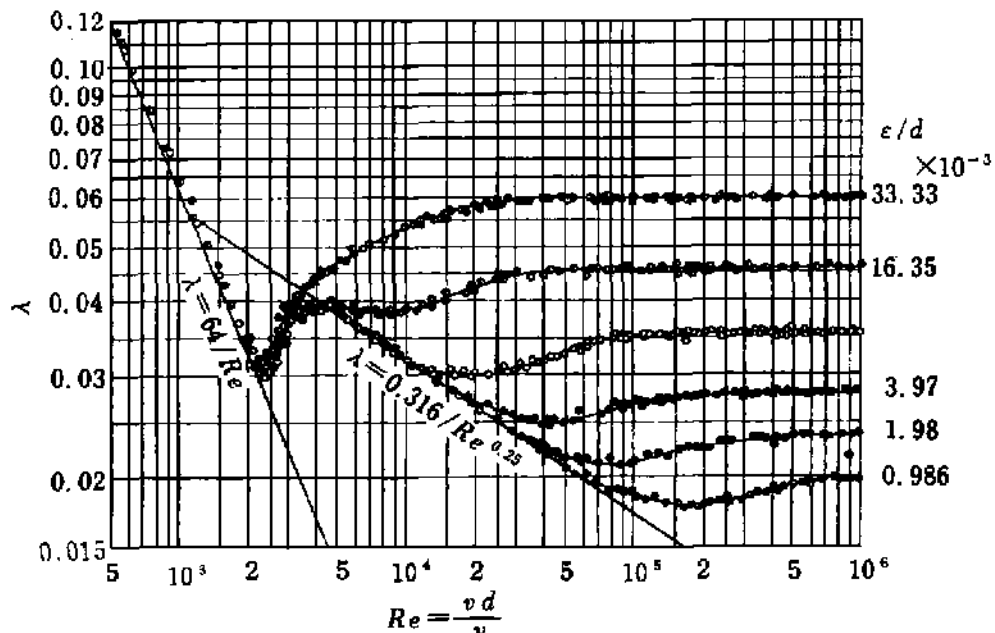

Fig. 7.4 Friction coefficient of coarse circular pipe with sand grains

² Itaya, M., *Journal of JSME*, 48 (1945), 84.

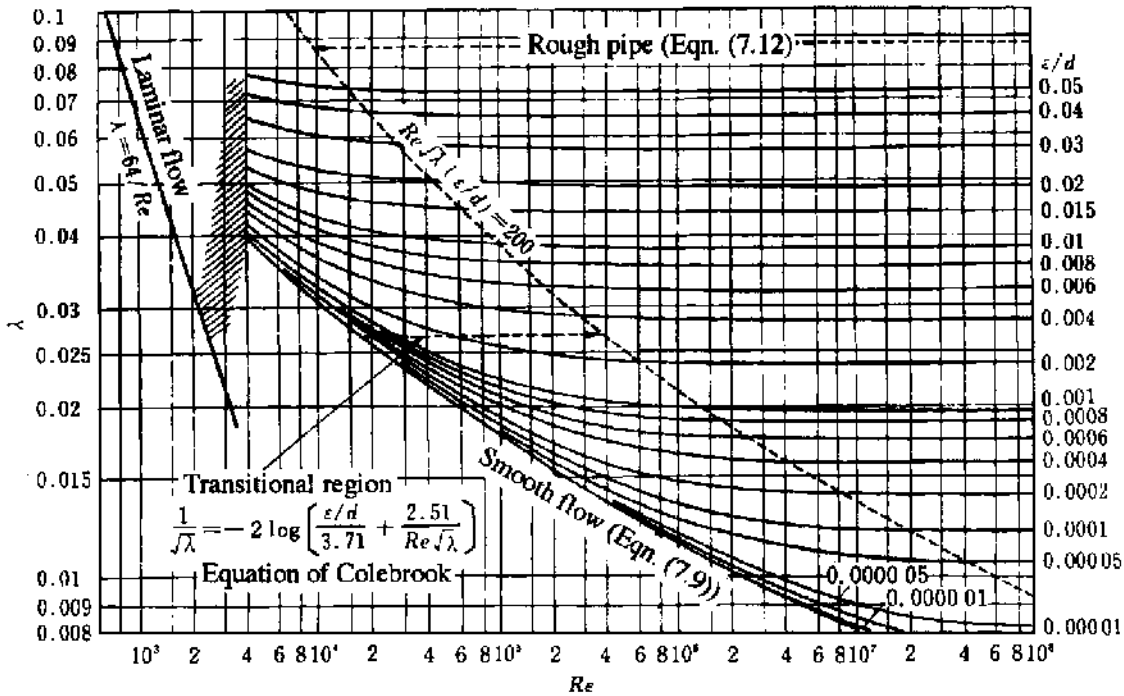

Fig. 7.5 Moody diagram

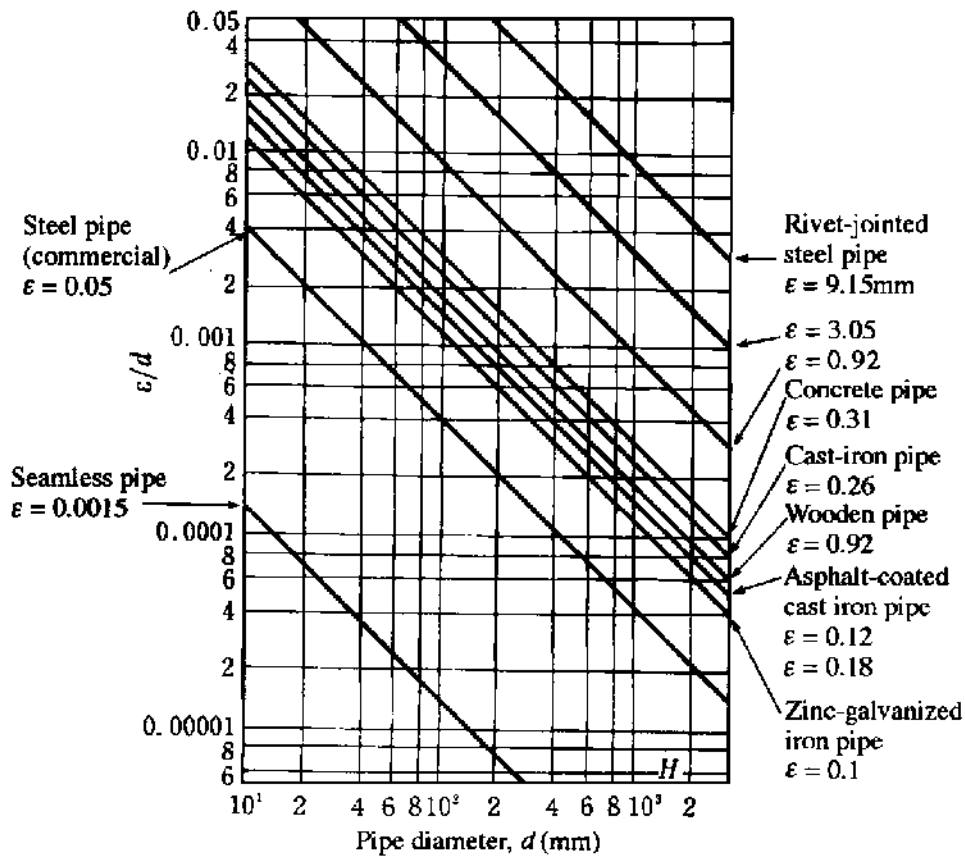

Fig. 7.6 Roughness of commercial pipe

According to this result, whenever $Re > 900(\varepsilon/d)$, it turns out that

$$\lambda = \frac{1}{[1.74 - 2 \log_{10}(2\varepsilon/d)]^2} \quad (7.12)$$

The velocity distribution for this case is expressed by the following equation:

$$u/v_* = 8.48 + 5.75 \log_{10}(y/\varepsilon) \quad (7.13)$$

For a pipe of irregular coarseness found in practice, the Moody diagram³ shown in Fig. 7.5 is applicable. For a new commercial pipe, λ can be easily obtained from Fig. 7.5 using ε/d in Fig. 7.6.

7.3 Frictional loss on pipes other than circular pipes

In the case of a pipe other than a circular one (e.g. oblong or oval), how can the pressure loss be found?

Where fluid flows in an oblong pipe as shown in Fig. 7.7, let the pressure drop over length l be h , the sides of the pipe be a and b respectively, and the wall perimeter in contact with the fluid on the section be s , where the shearing stress is τ_0 , the shearing force acting on the pipe wall of length l is $l\tau_0s$, and the balancing pressure force is ρghA . Then

$$\rho ghA = \tau_0sl \quad (7.14)$$

This equation shows that for a given pressure loss τ_0 is determined by A/s (the ratio of the flow section area to the wetted perimeter). $A/s = m$ is called the hydraulic mean depth (see Section 8.1). In the case of a filled circular section pipe, since $A = (\pi/4)d^2$, $s = \pi d$, the relationship $m = d/4$ is obtained. So, for pipes other than circular, calculation is made using the following equation and substituting $4m$ (which is called the hydraulic diameter) as the representative size in place of d in eqn (7.4):

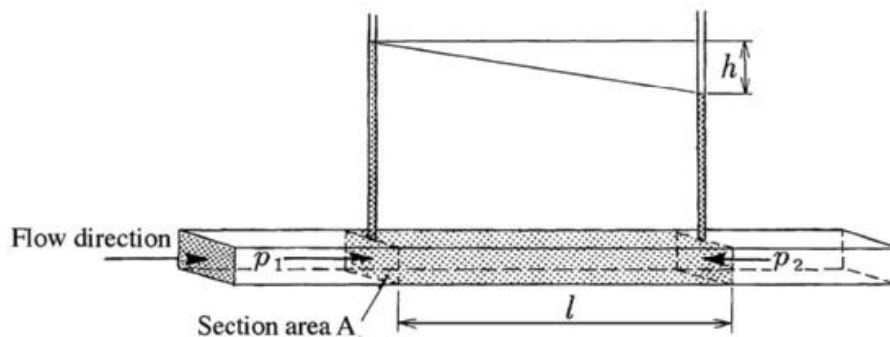

Fig. 7.7 Flow in oblong pipe

³ Moody, L.F. and Princeton, N.J., *Transactions of the ASME*, 66 (1944), 671.

$$h = \lambda \frac{l}{4m} \frac{v^2}{2g} \quad \lambda = f(Re, \varepsilon/4m) \quad (7.15)$$

Here, assuming $Re = 4mv/\nu$, $\varepsilon/d = \varepsilon/4m$ may be found from the Moody diagram for a circular pipe. Meanwhile, $4m$ is described by the following equations respectively for an oblong section of a by b and for co-axial pipes of inner diameter d_1 and outer diameter d_2 :

$$4 \frac{ab}{2(a+b)} = \frac{2ab}{a+b} \quad 4 \frac{(\pi/4)(d_2^2 - d_1^2)}{\pi(d_1 + d_2)} = d_2 - d_1 \quad (7.16)$$

7.4 Various losses in pipe lines

In a pipe line, in addition to frictional loss, head loss is produced through additional turbulence arising when fluid flows through such components as change of area, change of direction, branching, junction, bend and valve. The loss head for such cases is generally expressed by the following equation:

$$h_s = \zeta \frac{v^2}{2g} \quad (7.17)$$

v in the above equation is the mean flow velocity on a section not affected by the section where the loss head is produced. Where the mean flow velocity changes upstream or downstream of the loss-producing section, the larger of the flow velocities is generally used.

7.4.1 Loss with sudden change of area

Flow expansion

The flow expansion loss h_s for a suddenly widening pipe becomes the following, as already shown by eqn (5.44):

$$h_s = \frac{(v_1 - v_2)^2}{2g} = \left(1 - \frac{A_1}{A_2}\right)^2 \frac{v_1^2}{2g} \quad (7.18)$$

In practice, however, it becomes

$$h_s = \xi \frac{(v_1 - v_2)^2}{2g} \quad (7.19)$$

or as follows:

$$h_s = \zeta \frac{v_1^2}{2g} \quad (7.20)$$

$$\zeta = \xi \left(1 - \frac{A_1}{A_2}\right)^2 \quad (7.21)$$

Here, ζ is a value near one.

At the outlet of the pipe as shown in Fig. 7.8, since $v_2 = 0$, eqn (7.19) becomes

$$h_s = \xi \frac{v_1^2}{2g} \quad (7.22)$$

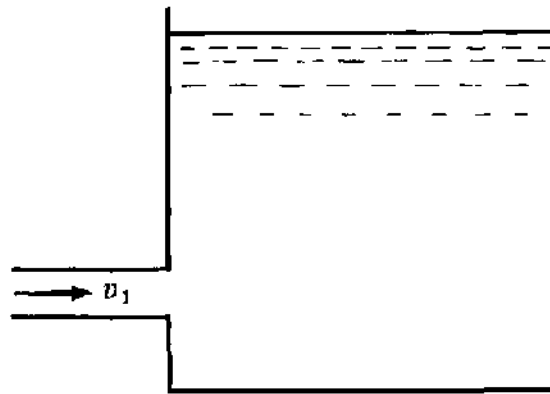

Fig. 7.8 Outlet of pipe line

Flow contraction

Owing to the inertia, section 1 (section area A_1) of the fluid (Fig. 7.9) shrinks to section 2 (section area A_c), and then widens to section 3 (section area A_2). The loss when the flow is accelerated is extremely small, followed by a head loss similar to that in the case of sudden expansion. Like eqn (7.18), it is expressed by

$$h_s = \frac{(v_c - v_2)^2}{2g} = \left(\frac{A_2}{A_c} - 1 \right)^2 \frac{v_2^2}{2g} = \left(\frac{1}{C_c} - 1 \right)^2 \frac{v_2^2}{2g} \quad (7.23)$$

Here $C_c = A_c/A_2$ is a contraction coefficient. For example, when $A_2/A_1 = 0.1$, $C_c = 0.61$.⁴

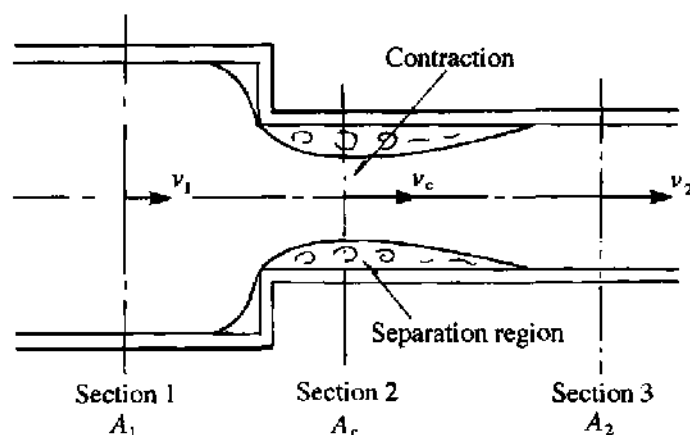

Fig. 7.9 Sudden contraction pipe

⁴ Summarised in Donald S. Miller *Internal Flow Systems*, British Hydromechanics Research Association (1978).

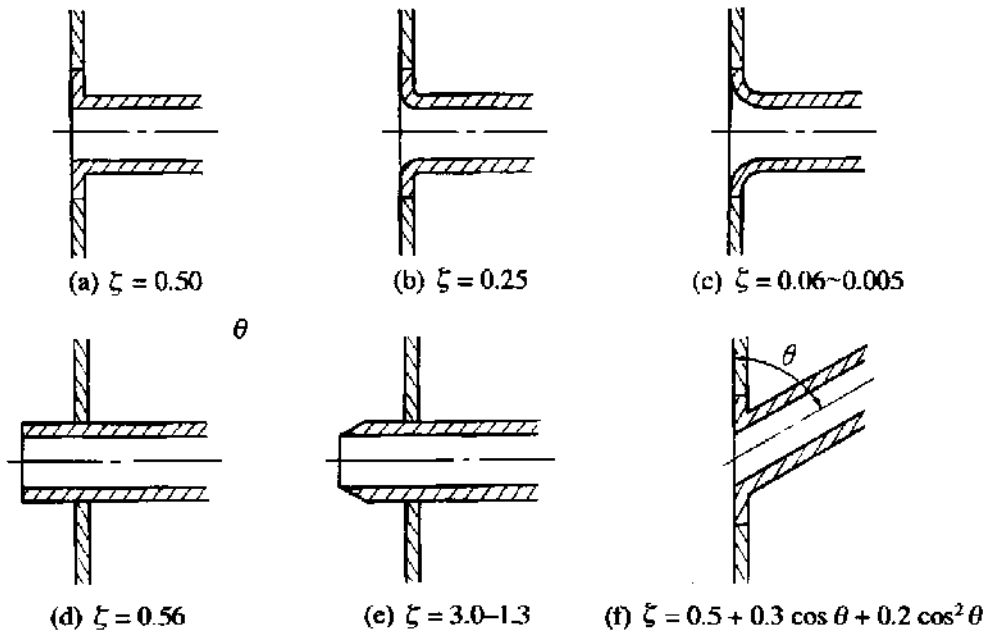

Fig. 7.10 Inlet shape and loss factor

Inlet of pipe line As shown in Fig. 7.10, the loss of head in the case where fluid enters from a large vessel is expressed by the following equation:

$$h_s = \zeta \frac{v^2}{2g} \tag{7.24}$$

In this case, however, ζ is the inlet loss factor and v is the mean flow velocity in the pipe. The value of ζ will be the value as shown in Fig. 7.10.⁵

Throttle A device which decreases the flow area, bringing about the extra resistance in a pipe, is generally called a throttle. There are three kinds of throttle, i.e. choke, orifice and nozzle. If the length of the narrow section is long compared with its diameter, the throttle is called a choke. Since the orifice is explained in Sections 5.2.2 and 11.2.2, and a nozzle is dealt with in Section 11.2.2, only the choke will be explained here.

The coefficient of discharge C in Fig. 7.11 can be expressed as follows, as eqn (5.25), where the difference between the pressure upstream and downstream of the throttle is Δp :

$$Q = C \frac{\pi d^2}{4} \sqrt{\frac{2\Delta p}{\rho}} \tag{7.25}$$

and C is expressed as a function of the choke number $\sigma = Q/vl$. C is as shown in Fig. 7.12, and is expressed by the following equations:⁶ if the entrance is

⁵ Weisbach, J., *Ingenieur- und Maschinen-Mechanik*, I (1896), 1003.

⁶ Hibi, et al., *Journal of the Japan Hydraulics & Pneumatics Society*, 2 (1971), 72.

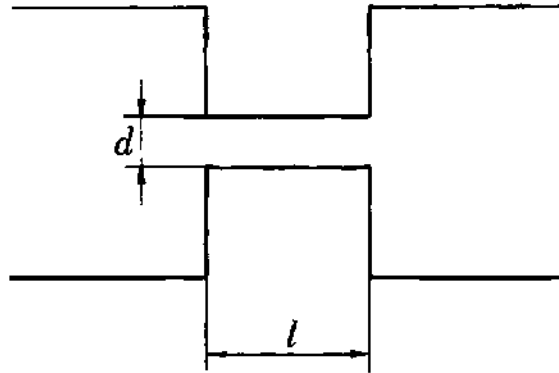

Fig. 7.11 Choke

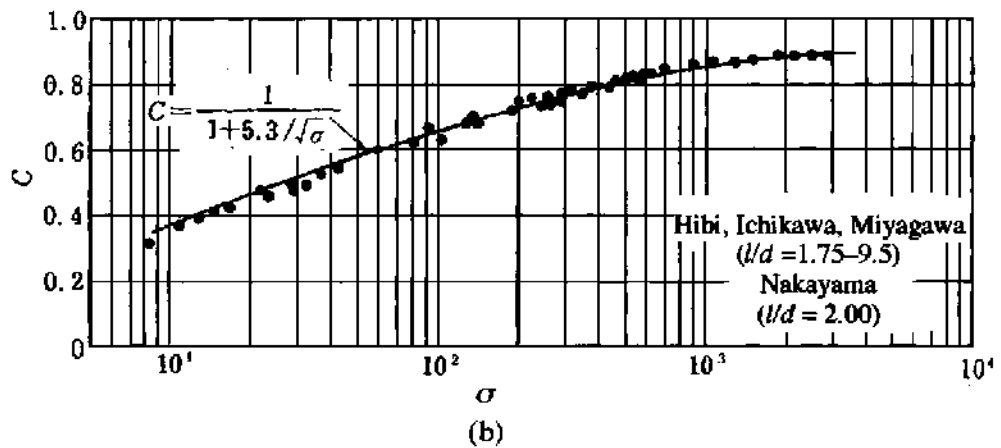
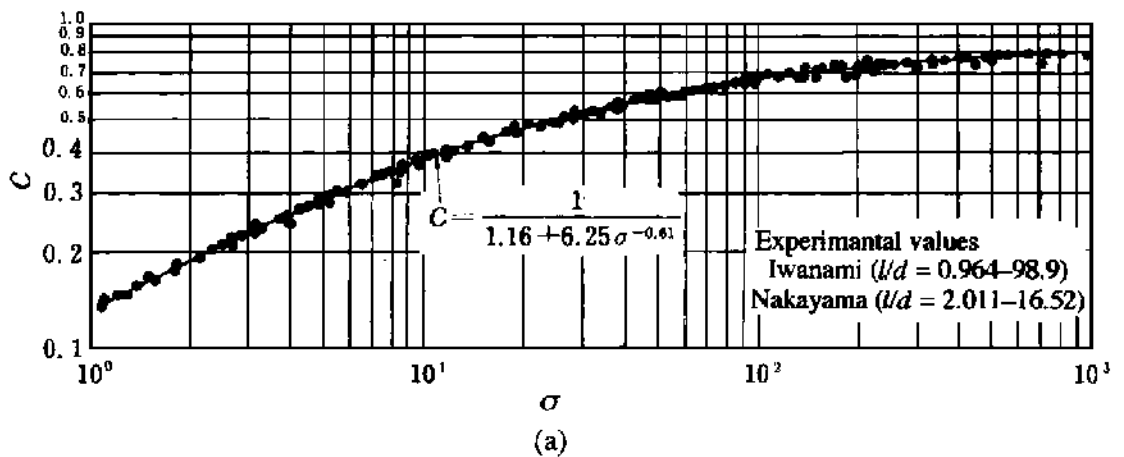

Fig. 7.12 Coefficient of discharge for cylindrical chokes: (a) entrance rounded; (b) entrance not rounded

rounded:

$$C = \frac{l}{1.16 + 6.25\sigma^{-0.61}} \tag{7.26}$$

and if the entrance is not rounded:

$$C = \frac{l}{1 + 5.3/\sqrt{\sigma}} \tag{7.27}$$

7.4.2 Loss with gradual change of area

Divergent pipe or diffuser

The head loss for a divergent pipe as shown in Fig. 7.13 is expressed in the same manner as eqn (7.19) for a suddenly widening pipe:

$$h_s = \xi \frac{(v_1 - v_2)^2}{2g} \quad (7.28)$$

The value of ξ for circular divergent pipes is shown in Fig. 7.14.⁷ The value of ξ varies according to θ . For a circular section $\xi = 0.135$ (minimum) when $\theta = 5^\circ 30'$. For the rectangular section, $\xi = 0.145$ (minimum) when $\theta = 6^\circ$, and $\xi = 1$ (almost constant) whenever $\theta = 50^\circ - 60^\circ$ or more.

For a two-dimensional duct, if θ is small the fluid flows attaches to one of the side walls due to a wall attachment phenomenon (the wall effect).⁸ In the case of a circular pipe, when θ becomes larger than the angle which gives the minimum value of ξ , the flow separates midway as shown in Fig. 7.15. Owing to the turbulence accompanying such a separation of flow, the loss of head suddenly increases. This phenomenon is visualised in Fig. 7.16.

A divergent pipe is also used as a diffuser to convert velocity energy into pressure energy. In the case of Fig. 7.13, the following equation is obtained by applying Bernoulli's principle:

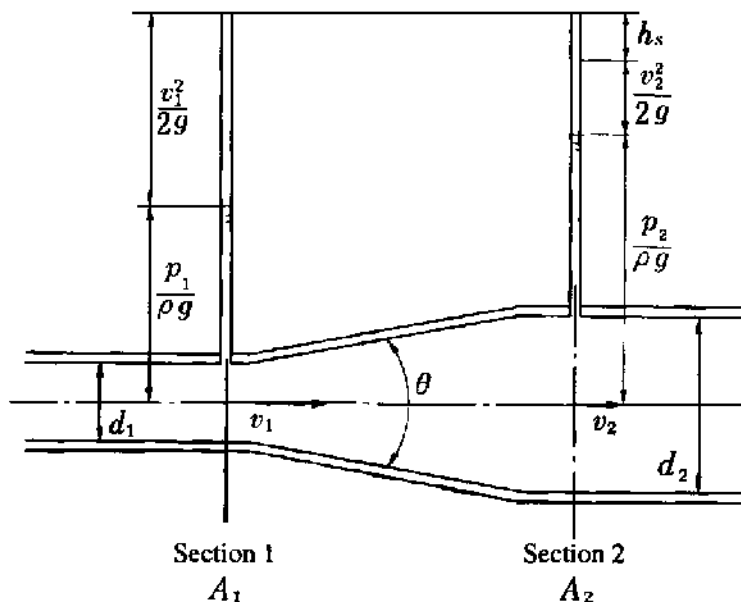

Fig. 7.13 Divergent flow

⁷ Gibson, A. H., *Hydraulics*, (1952), 91, Constable, London; Uematsu, T., *Bulletin of JSME*, 2 (1936), 254.

⁸ An adjacent wall restricts normal flow entrainment by a jet. A fall in pressure results which deflects the jet such that it can become attached to the wall. This is called the Coanda effect, discovered by H. Coanda in 1932. The effect is the basic principle of the technology of fluidics.

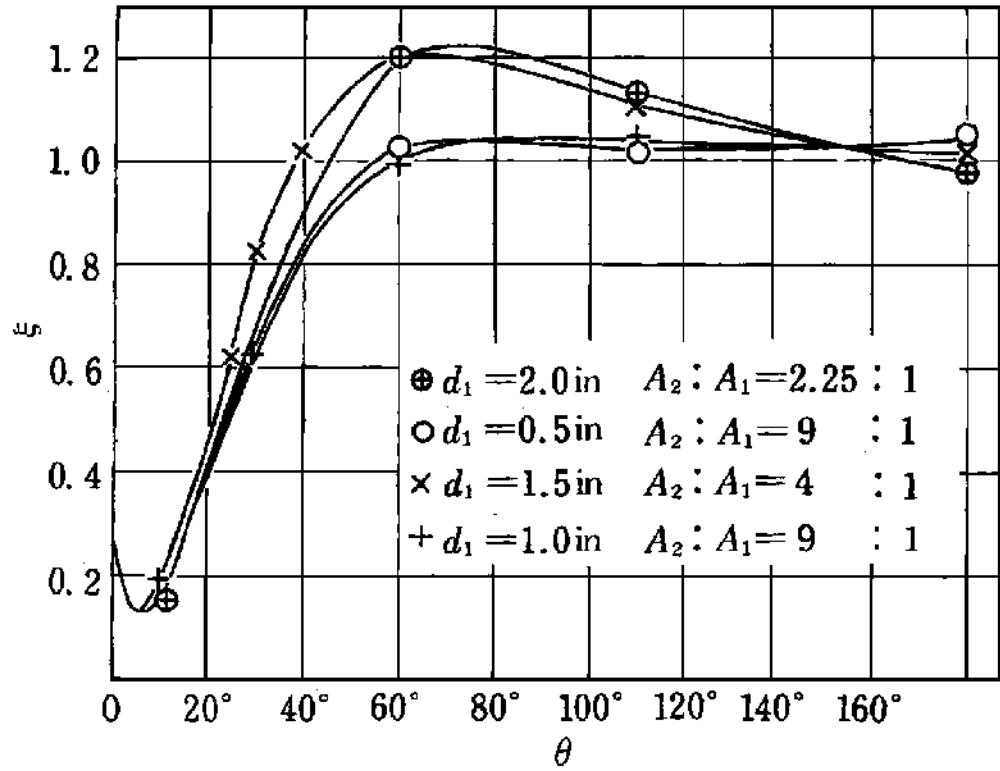

Fig. 7.14 Loss factor for divergent pipes

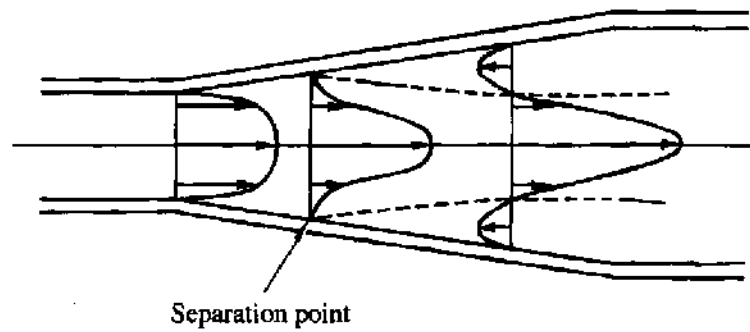

Fig. 7.15 Velocity distribution in a divergent pipe

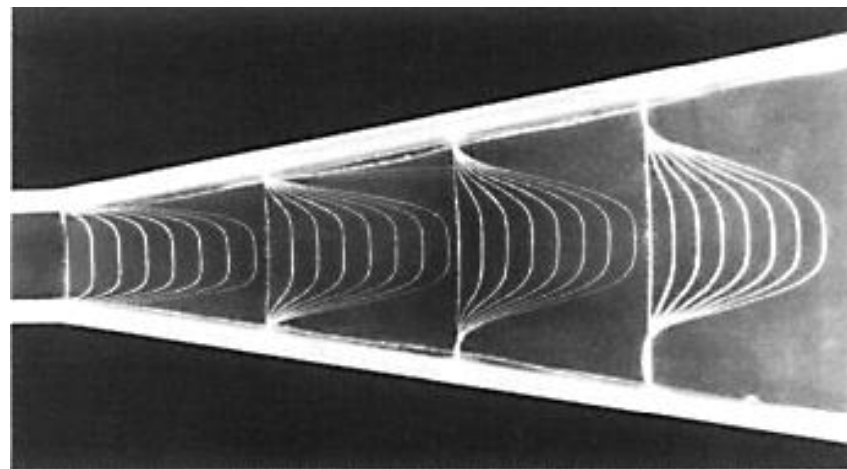

Fig. 7.16 Separation occurring in a divergent pipe (hydrogen bubble method), in water; inlet velocity 6 cm/s, Re (inlet port) = 900, divergent angle 20°

$$\frac{p_1}{\rho g} + \frac{v_1^2}{2g} = \frac{p_2}{\rho g} + \frac{v_2^2}{2g} + h_s$$

Therefore

$$\frac{p_2 - p_1}{\rho g} = \frac{v_1^2 - v_2^2}{2g} - h_s \quad (7.29)$$

Putting p_{2th} for p_2 for the case where there is no loss,

$$\frac{p_{2th} - p_1}{\rho g} = \frac{v_1^2 - v_2^2}{2g} \quad (7.30)$$

The pressure recovery efficiency η for a diffuser is therefore

$$\eta = \frac{p_2 - p_1}{p_{2th} - p_1} = 1 - \frac{h_s}{(v_1^2 - v_2^2)/2g} \quad (7.31)$$

Substituting in eqn (7.28), the above equation becomes

$$\eta = 1 - \xi \frac{v_1 - v_2}{v_1 + v_2} = 1 - \xi \frac{1 - A_1/A_2}{1 + A_1/A_2} \quad (7.32)$$

Convergent pipe

In the case where a pipe section gradually becomes smaller, since the pressure decreases in the direction of the flow, the flow runs freely without extra turbulence. Therefore, losses other than the pipe friction are normally negligible.

7.4.3 Loss whenever the flow direction changes

Bend

The gently curving part of a pipe shown in Fig. 7.17 is referred to as a pipe

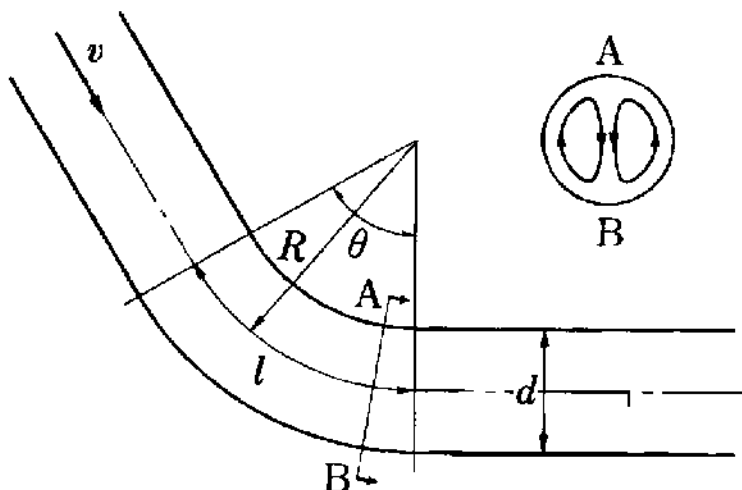

Fig. 7.17 Bend

Table 7.1 Loss factor ζ for bends (smooth wall $Re = 225\,000$, coarse wall face $Re = 146\,000$)

Wall face	θ°	$R/d = 1$	2	3	4	5
Smooth	15°	0.03	0.03	0.03	0.03	0.03
	22.5°	0.045	0.045	0.045	0.045	0.045
	45°	0.14	0.14	0.08	0.08	0.07
	60°	0.19	0.12	0.095	0.085	0.07
	90°	0.21	0.135	0.10	0.085	0.105
Coarse	90°	0.51	0.51	0.23	0.18	0.20

bend. In a bend, in addition to the head loss due to pipe friction, a loss due to the change in flow direction is also produced. The total head loss h_b is expressed by the following equation:

$$h_b = \zeta_b \frac{v^2}{2g} = \left(\zeta + \lambda \frac{l}{d} \right) \frac{v^2}{2g} \quad (7.33)$$

Here, ζ_b is the total loss factor, and ζ is the loss factor due to the bend effect. The values of ζ are shown in Table 7.1.⁹

In a bend, secondary flow is produced as shown in the figure owing to the introduction of the centrifugal force, and the loss increases. If guide blades are fixed in the bend section, the head loss can be very small.

Elbow

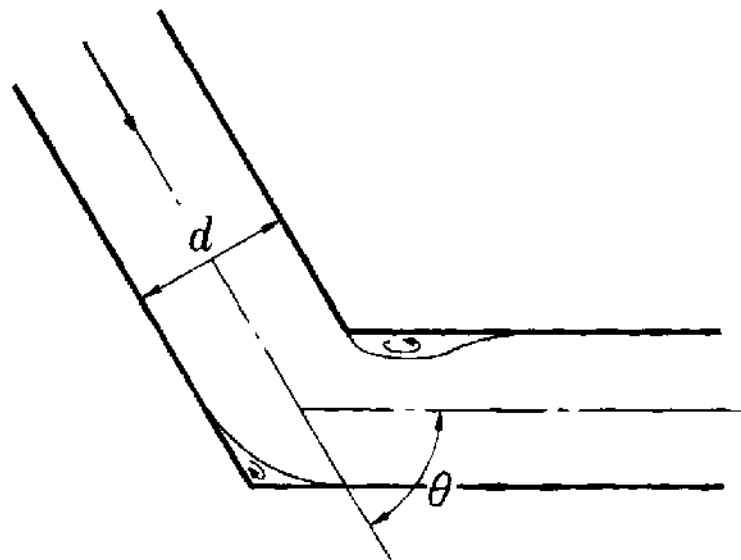
**Fig. 7.18** Elbow

⁹ Hoffman, A., *Mtt. Hydr. Inst. T. H. München*, 3 (1929), 45; Wasielewski, R. *Mitt. Hydr. Inst. T. H. München*, 5 (1932), 66.

As shown in Fig. 7.18, the section where the pipe curves sharply is called an elbow. The head loss h_b is given in the same form as eqn (7.33). Since the flow separates from the wall in the curving part, the loss is larger than in the case of a bend. Table 7.2 shows values of ζ for elbows.¹⁰

Table 7.2 Loss factor ζ for elbows

θ°		5°	10°	15°	22.5°	30°	45°	60°	90°
ζ	Smooth	0.016	0.034	0.042	0.066	0.130	0.236	0.471	1.129
	Coarse	0.024	0.044	0.062	0.154	0.165	0.320	0.687	1.265

7.4.4 Pipe branch and pipe junction

Pipe branch

As shown in Fig. 7.19, a pipe dividing into separate pipes is called a pipe branch. Putting h_{s1} as the head loss produced when the flow runs from pipe ① to pipe ③, and h_{s2} as the head loss produced when the flow runs from pipe ① to pipe ②, these are respectively expressed as follows:

$$h_{s1} = \zeta_1 \frac{v_1^2}{2g} \quad h_{s2} = \zeta_2 \frac{v_1^2}{2g} \quad (7.34)$$

Since the loss factors ζ_1, ζ_2 vary according to the branch angle θ , diameter ratio d_1/d_2 or d_1/d_3 and the discharge ratio Q_1/Q_2 or Q_1/Q_3 , experiments were performed for various combinations. Such results were summarised.¹¹

Pipe junction

As shown in Fig. 7.20, two pipe branches converging into one are called a pipe junction. Putting h_{s1} as the head loss when the flow runs from pipe ① to pipe ③, and h_{s2} as the head loss when the flow runs from pipe ② to pipe ③, these are expressed as follows:

$$h_{s1} = \zeta_1 \frac{v_3^2}{2g} \quad h_{s2} = \zeta_2 \frac{v_3^2}{2g} \quad (7.35)$$

Values of ζ_1 and ζ_2 are similar to the case of the pipe branch.

¹⁰ Kirchbach, H. und Schubart, W., *Mitt. Hydr. Inst. T. H. München*, 2 (1929), 72; 3 (1929), 121.

¹¹ Vogel G., *Mitt. Hydr. Inst. T. M. München*, 1 (1926), 75; 2 (1928), 61; Peter-Mann, F., *Mitt. Inst. T. H. München*, 3 (1929), 98.

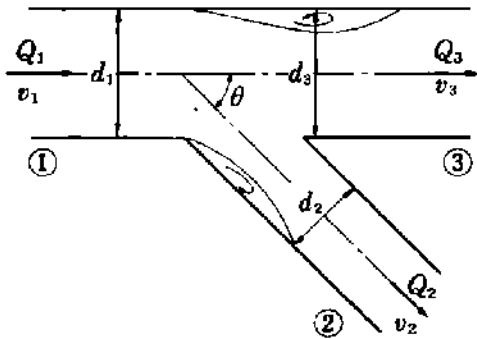

Fig. 7.19 Pipe branch

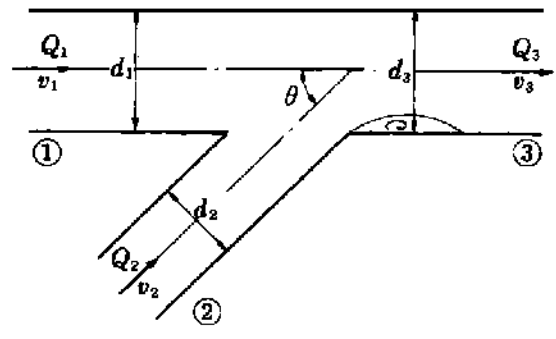

Fig. 7.20 Pipe junction

7.4.5 Valve and cock

Head loss on valves is brought about by changes in their section areas, and is expressed by eqn (7.17) provided that v indicates the mean flow velocity at the point not affected by the valve.

Gate valve

The valve as shown in Fig. 7.21 is called a gate valve. Putting d as the diameter and d' as the valve opening, ζ varies according to d'/d . Table 7.3 shows values of ζ for a 1 inch (2.54 cm) nominal diameter valve.¹²



Fig. 7.21 Gate valve

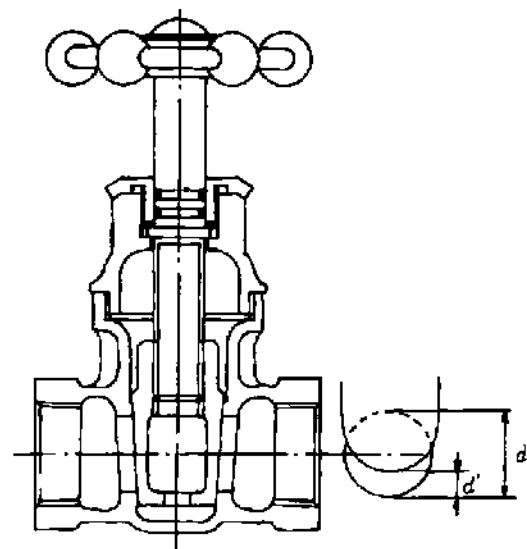

¹² Corp, C.I., *Bulletin of the University of Wisconsin, Engineering Series*, 9-1 (1922), 1.

Globe valve

Table 7.4 shows values of ζ for the globe valve shown in Fig. 7.22, at various openings.¹³

Table 7.3 Values for ζ for 1 inch gate valves ($d = 25.5$ mm)

d'/d	1/8	1/4	3/8	1/2	3/4	1
ζ	211	40.3	10.15	3.54	0.882	0.233

Table 7.4 Values of ζ for 1 inch screw-in globe valves ($d = 25.5$ mm)

l/d	1/4	1/2	3/4	1
ζ	16.3	10.3	7.63	6.09

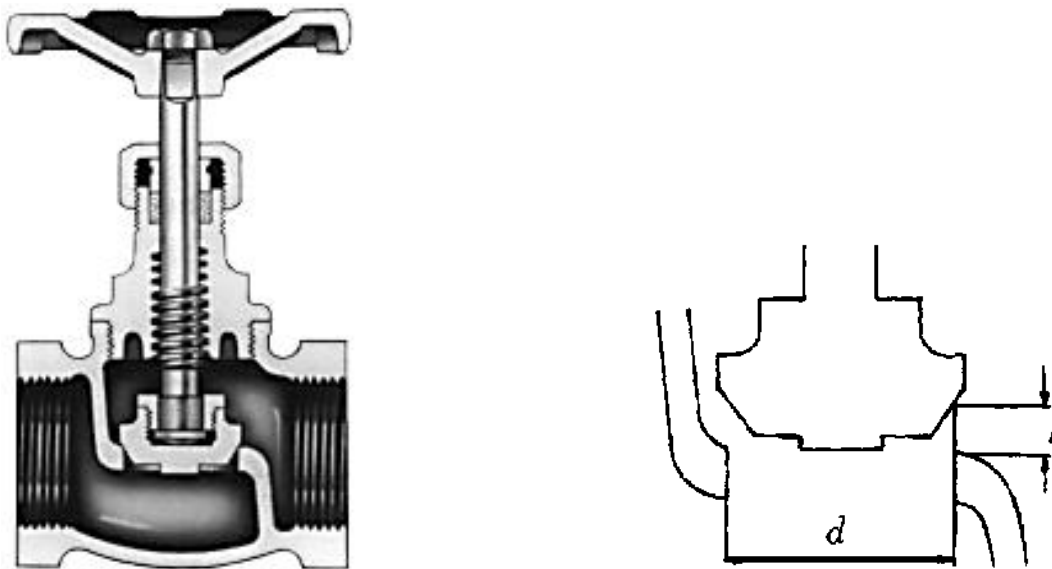

Fig. 7.22 Globe valve

Butterfly valve (Fig. 7.23)

Table 7.5 shows values of ζ for a butterfly valve.¹⁴ As the inclination angle θ of the valve plate increases, the section area immediately downstream of the valve suddenly increases, bringing about an increased value of ζ .

¹³ Oki, I., *Suirikigaku* (Hydraulics), 344, Iwanami, Tokyo. In addition, for popet valves, Ichikawa, T. and Shimizu, T., 31 (1965), 317; Kasai, K., *Trans. JSME*, 33 (1967), 1088.

¹⁴ Weisbach, J., *Ingenieur- und Maschinen-Mechanik*, I (1896), 1050.

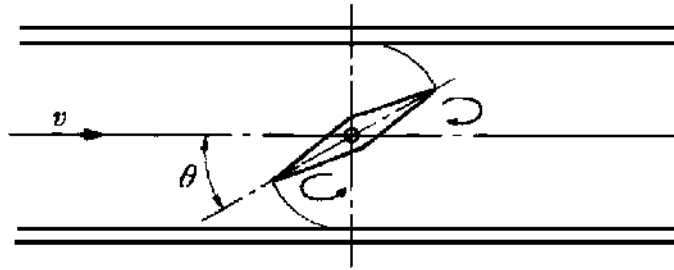

Fig. 7.23 Butterfly valve

Table 7.5 Values of ζ for circular butterfly valves

θ°	10°	20°	30°	50°	70°
ζ	0.52	1.54	3.91	32.6	751

For a circular butterfly valve, when $\theta = 0^\circ$, the value of ζ is

$$\zeta = t/d \tag{7.36}$$

Cock (Fig. 7.24)

Table 7.6 shows values of ζ for a cock. For cocks, too, as angle θ increases, large changes in section area of flow are brought about, increasing the value of ζ .

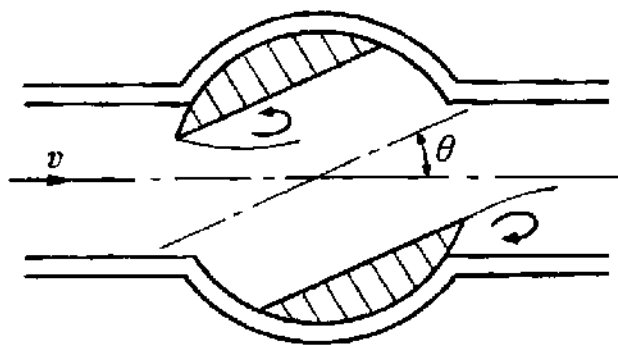

Fig. 7.24 Cock

Table 7.6 Values of ζ for cocks

θ°	10°	30°	50°	60°
ζ	0.29	5.47	52.6	206

Other valves

Values of ζ for various valves are shown in Table 7.7.¹⁵

Table 7.7 Loss factor for various valves

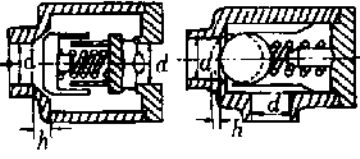
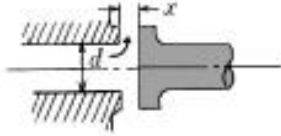
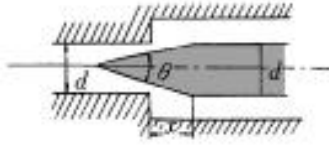
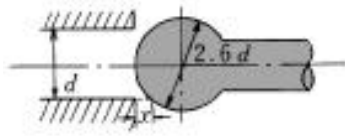
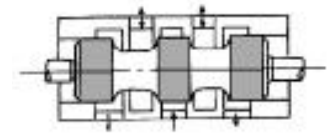
Valve	Loss coefficients, ζ														
<p>Relief valve</p> 	<table border="1"> <tr> <td>h/d</td> <td>0.05</td> <td>0.1</td> <td>0.15</td> <td>0.2</td> <td>0.25</td> <td>0.3</td> </tr> <tr> <td>ζ</td> <td>3.35</td> <td>2.85</td> <td>2.4</td> <td>2.4</td> <td>1.7</td> <td>1.35</td> </tr> </table>	h/d	0.05	0.1	0.15	0.2	0.25	0.3	ζ	3.35	2.85	2.4	2.4	1.7	1.35
h/d	0.05	0.1	0.15	0.2	0.25	0.3									
ζ	3.35	2.85	2.4	2.4	1.7	1.35									
<p>Disc valve</p> 	<p>Throttle area $a = \pi dx$ Section area of valve seat hole $A = \pi d^2/4$ When $x = d/4$ $a = A$ Loss coefficient $\zeta = 1.3 + 0.2(A/a)^2$</p>														
<p>Needle valve</p> 	<p>$a = \pi(dx \tan \theta/2 - x^2 \tan^2 \theta/2)$ $Ax = 0$ when $x = 0$ $\zeta = 0.5 + 0.15(A/a)^2$</p>														
<p>Ball valve</p> 	<p>$a \simeq 0.75\pi dx$ $\zeta = 0.5 + 0.15(A/a)^2$</p>														
<p>Spool valve</p> 	<p>At full open position $\zeta = 3 \sim 5.5$</p>														

7.4.6 Total loss along a pipe line

For a pipe with flow velocity v , inner diameter d and length l , the total loss from pipe entrance to exit is

$$h = \left(\lambda \frac{l}{d} + \sum \zeta \right) \frac{v^2}{2g} \tag{7.37}$$

¹⁵ Yeaple, F. D., *Hydraulic and Pneumatic Power Control*, (1966), 89, McGraw-Hill, New York.

The first term on the right expresses the total loss by friction, while $\sum \zeta(v^2/2g)$ represents the sum of the loss heads at such sections as the entrance, bend and valve. Whenever a pipe line consists of pipes of different diameters, it is necessary to use the appropriate value for the flow velocity for each pipe.

When two tanks with a water-level differential h are connected by a pipe line, the exit velocity energy is generally lost. Therefore,

$$h = \left(\lambda \frac{l}{d} + \sum \zeta + 1 \right) \frac{v^2}{2g} \tag{7.38}$$

However, when the pipe line is long such that $l/d > 2000$ and it has no valves of small opening etc., losses other than frictional loss may be neglected.

Conversely, if h is known, the flow velocity could be obtained from eqn (7.37) or eqn (7.38).

In general, for urban water pipes, $v = 1.0 \sim 1.5$ m/s is typical for long pipe runs, while up to approximately 2.5 m/s is typical for short pipe runs. For the headrace of a hydraulic power plant, 2 ~ 5 m/s is the usual range.

7.5 Pumping to higher levels

A pump can deliver to higher levels since it gives energy to the water (Fig. 7.25). The head H across the pump is called the total head. The differential

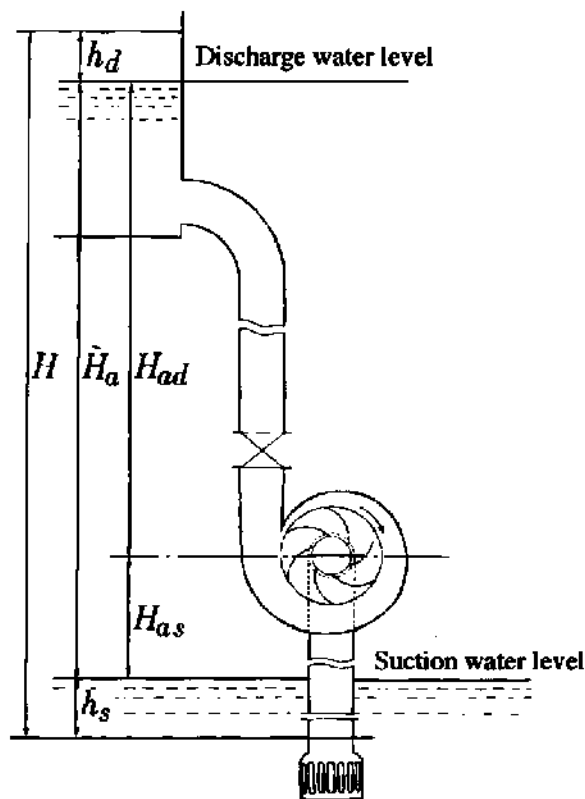

Fig. 7.25 Storage pump: H total head; \hat{H}_a actual head; $H_{a,s}$ suction head; $H_{a,d}$ discharge head; h_s losses on suction s; h_d losses on discharge side

height H_a between two water levels is called the actual head and

$$H = H_a + h \quad (7.39)$$

where h is the sum of h_s and h_d expressing the total loss.

The volume of water which passes through a pump in unit time is called the pump discharge. Since the energy which a pump gives water in a unit time is H per unit weight, the energy L_w given to water per unit time is

$$L_w = \rho g Q H \quad (7.40)$$

This is sometimes known as the water horsepower.

The power L_s needed by a pump is called the shaft horsepower:

$$L_w/L_s = \eta \quad (7.41)$$

where η is the efficiency of the pump. Since the energy supplied to a pump is not all transmitted to the water due to the energy loss within the pump, it turns out that $\eta < 1$.

As shown in Fig. 7.26, the curve which expresses the relationship between the pump discharge Q and the head H is called the characteristic curve or head curve. In general, the head loss h is proportional to the square of the mean flow velocity in the pipe, and therefore to the square of the pump discharge, and is called the resistance curve. It must be summed with H_a to give the pump load curve.

The pump discharge is given, as shown in Fig. 7.26, by the intersecting point of the head curve and this load curve.

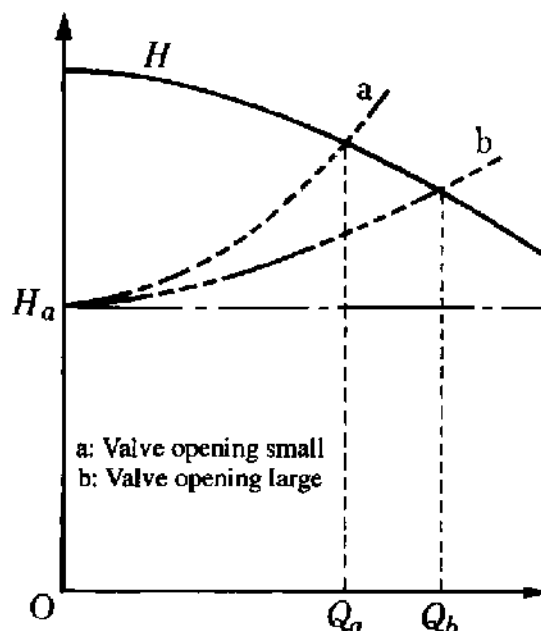

Fig. 7.26 Total head and load curve of pump

7.6 Problems

1. Verify that the kinetic energy for laminar flow in a circular pipe with a fully developed velocity distribution is twice that with uniform velocity.
2. What is the relationship between the flow velocity and the pressure loss in a circular pipe?
3. For laminar flow in a circular pipe, verify that the pipe frictional coefficient can be expressed by the following equation:

$$\lambda = 64/Re$$

4. For turbulent flow in a circular pipe, show that, assuming the pipe frictional coefficient is subject to $\lambda = 0.3164Re^{-1/4}$, the pressure loss is proportional to a power of 1.75 of the mean flow velocity.
5. For flow in a circular pipe, with constant pipe friction coefficient, show that the frictional head loss is inversely proportional to the fifth power of the pipe diameter. Also, if the diameter is measured with $\alpha\%$ error, what would be the percentage error in head loss?
6. How much head loss will be produced by sending $0.5 \text{ m}^3/\text{min}$ of water a distance of 2000 m using commercial steel pipes of diameter 50 mm? Also, what would be the head loss if the diameter is 100 mm? The water temperature is assumed to be 20°C .
7. What is the necessary shaft horsepower to send $1 \text{ m}^3/\text{min}$ of water through a conduit 100 mm in diameter as shown in Fig. 7.27? Assume pump efficiency $\eta = 80\%$, loss coefficient of sluice valve $\zeta_v = 0.175$, of 90° elbow $\zeta_{90} = 1.265$, of 45° elbow $\zeta_{45} = 0.320$, and pipe frictional coefficient $\lambda = 0.026$.

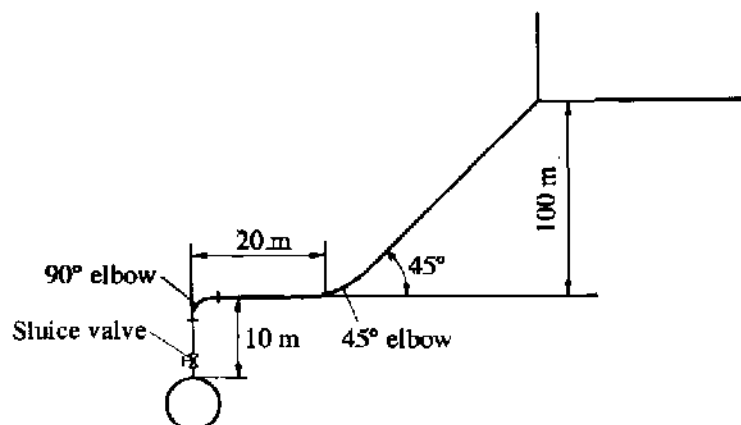

Fig. 7.27

8. A flow of $0.6 \text{ m}^3/\text{s}$ of air discharges through a square duct of sides 20 cm. What is the pressure loss if the duct length is 50 m? Assume an air temperature of 20°C , standard atmospheric pressure, and smooth walls for the duct.

9. Water flows through a sudden expansion where a circular pipe of 40 mm diameter is directly connected to one of 80 mm. If the discharge is $0.08 \text{ m}^3/\text{min}$, find the expansion loss.
10. Obtain the head loss and the pressure recovery rate when a circular pipe of 40 mm diameter is connected to one of 80 mm diameter by a 10° diffuser.