

Measurement of flow velocity and flow rate

To clarify fluid phenomena, it is necessary to measure such quantities as pressure, flow velocity and flow rate. Since the measurement of pressure was covered in Section 3.1.5, in this chapter we cover the measurement of flow velocity and flow rate. Fluid includes both gas and liquid. According to the type and condition of the fluid, or if it flows in a pipe line or open channel, various methods of measurement were developed and are in practical use.

11.1 Measurement of flow velocity

11.1.1 Pitot tube

Figure 11.1 shows the shape of a commonly used standard Pitot tube (also called a Pitot-static tube). The flow velocity is given by the following equation from total pressure p_1 and static pressure p_2 , both to be measured as in the case of eqn (5.20):

$$v = c\sqrt{2(p_1 - p_2)/\rho} \quad (11.1)$$

where c is called the Pitot tube coefficient, which may be taken as having value 1 for a standard-type Pitot tube. However, when compressibility is to be taken into account, refer to Section 13.4.

A Pitot tube is also used to measure the flow in a large-diameter pipe. In this case, the cross-section of the pipe is divided into ring-like equal areas, and the flow velocity at the centre of the area of every ring is measured. The mean flow velocity is obtained from their mean value, and the total flow rate is obtained from the product of the mean velocity and the section area. Apart from the standard type, there are various other types of Pitot tube, as follows.

Cylinder-type Pitot tube

This type of Pitot tube is used to measure simultaneously the direction and the flow velocity of a two-dimensional flow utilising the pressure distribution

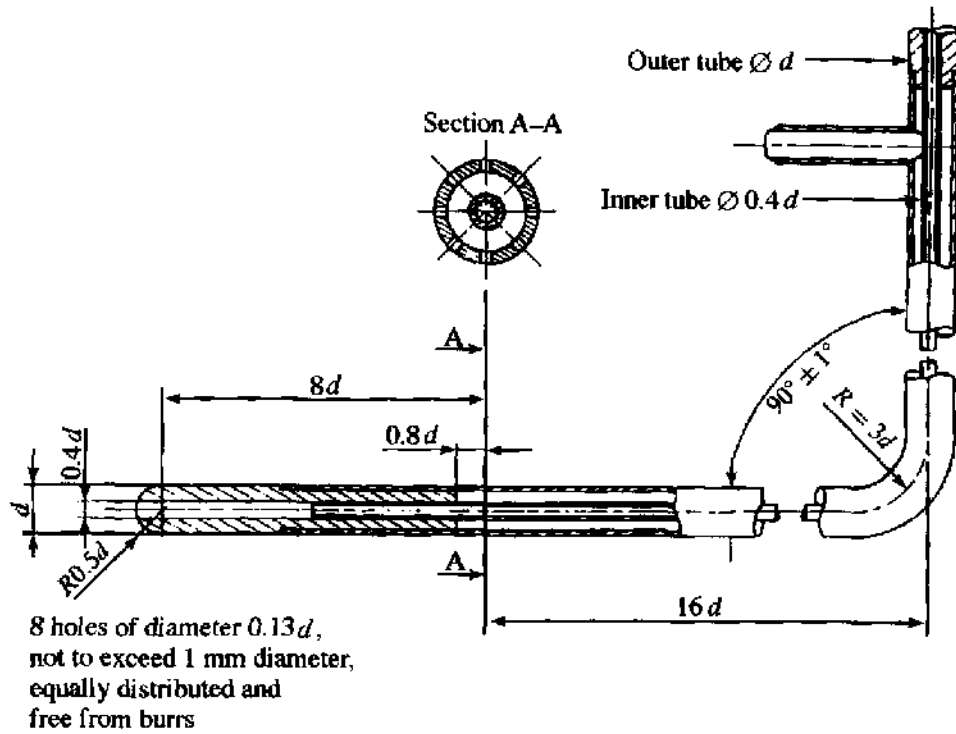

Fig. 11.1 NPL-type Pitot tube

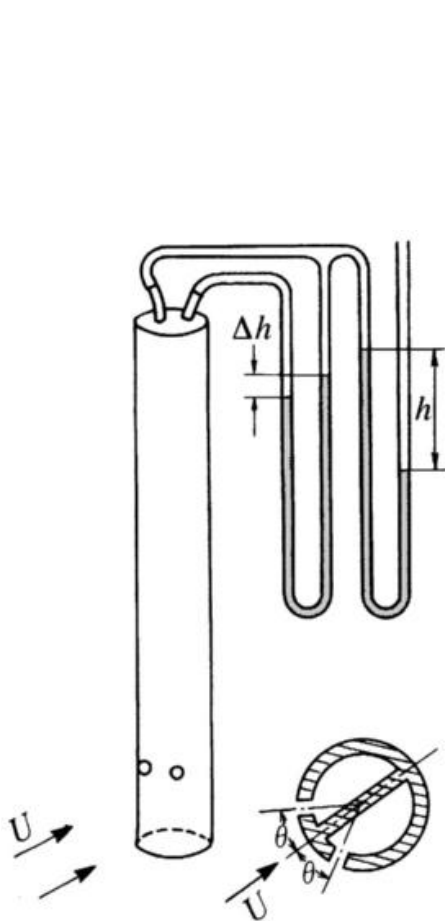

Fig. 11.2 Cylinder-type Pitot tube

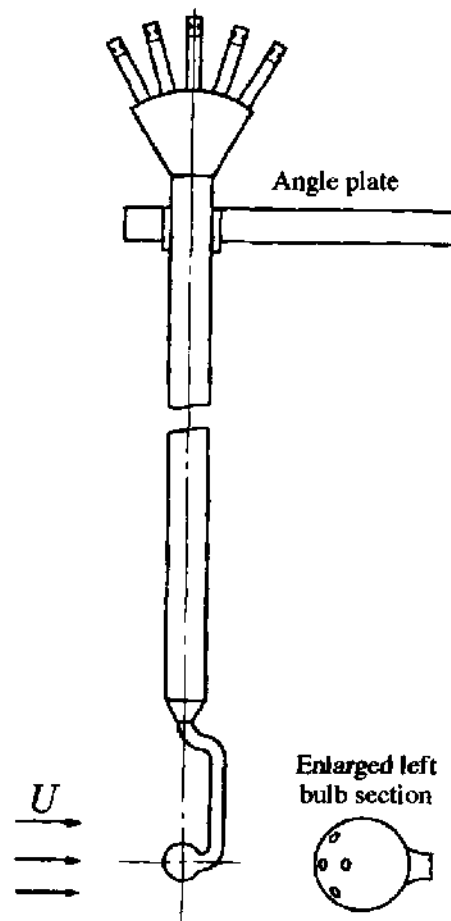

Fig. 11.3 Five-hole spherical Pitot tube

on the cylinder surface wall that is shown in Fig. 9.5. Figure 11.2 shows the measuring principle. The body is rotated in a flow until $\Delta h = 0$, and the centre-line direction is then the flow direction. The static pressure is obtained if $\theta = 33^\circ\text{--}35^\circ$. Then, if one of the holes is made to face the flow direction by rotating the cylinder, it measures the total pressure. If a third measuring hole is provided on the centre line, the flow direction and both pressures can be measured at the same time. A device which measures the flow direction and velocity in this way is called a yawmeter.

Five-hole spherical Pitot tube

This is constructed as shown in Fig. 11.3, and is capable of measuring the velocity and direction of a three-dimensional flow.

Pitot tube for measuring the flow velocity near the wall face

For measuring the velocity of a flow very near the wall face, a total pressure tube from a flattened fine tube as shown in Fig. 11.4(a) is used. For measuring the velocity of a flow even nearer to the wall face, a surface Pitot tube as shown in Fig. 11.4(b) is used. By changing the width of opening B while moving the tube, the whole pressure distribution can be determined. In this case, the static pressure is measured by another hole on the wall face.

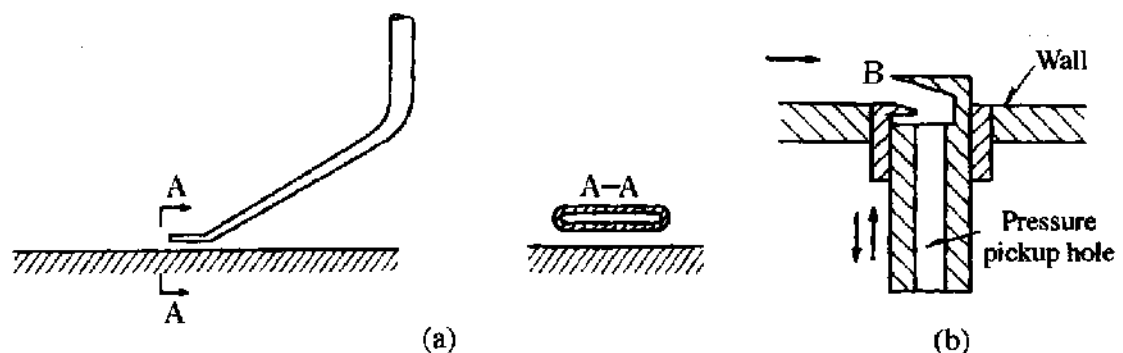

Fig. 11.4 Pitot tubes for measuring the velocity of flow near the wall face: (a) total pressure tube; (b) surface Pitot tube

11.1.2 Hot-wire anemometer

If a heated fine wire is placed in a flow, the temperature of the hot wire changes according to the velocity of the fluid so changing its electrical resistance. A meter which measures the flow by utilising this change in resistance is called a hot-wire anemometer.

One method is shown in Fig. 11.5(a). The flow velocity is obtained by reading the changing hot-wire temperature as a change of electrical resistance (using the galvanometer *G*) while keeping the voltage between *C* and *D* constant. This is called the constant voltage anemometer. A second method is shown in Fig. 11.5(b). The flow velocity is obtained by reading the voltmeter when the galvanometer (*G*) reading is zero after adjusting the variable

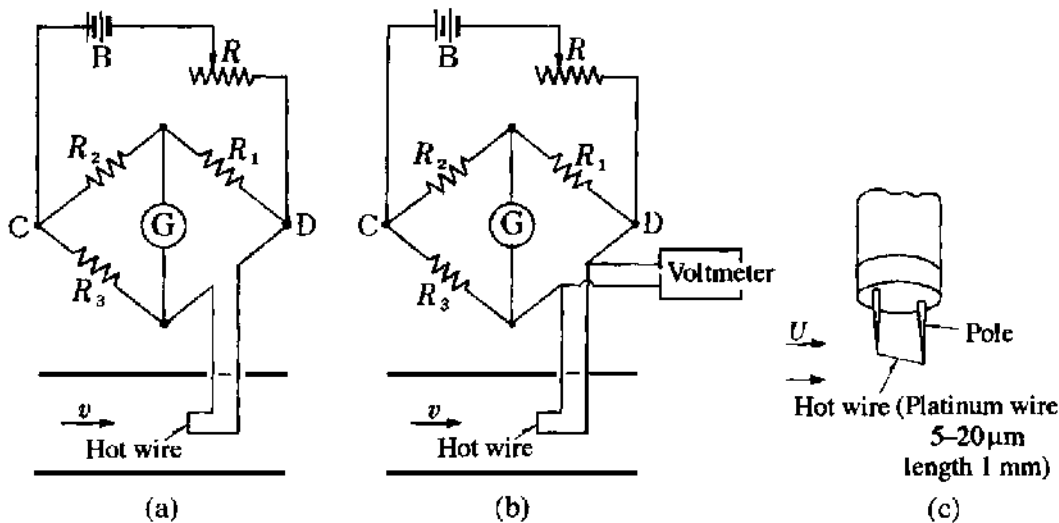

Fig. 11.5 Hot-wire anemometer: (a) constant voltage type; (b) constant temperature type; (c) probe

electrical resistance to maintain the hot-wire temperature, i.e. the electrical resistance, constant as the velocity changes. This is called the constant temperature anemometer (CTA).

Since the CTA has a good frequency response characteristic because thermal inertia effects are minimised, almost all currently used meters are of this type. It is capable of giving the flat characteristic up to a frequency of 100 kHz.

11.1.3 Laser Doppler anemometer

Point laser light at a tracer particle travelling with a fluid, and the scattered light from the particle develops a difference in frequency from the original incident light (reference light). This difference is due to the Doppler effect and is proportional to the particle velocity. A device by which the flow velocity is obtained from the velocity of tracer particles by measuring the difference in frequency f_D using a photocell or photodiode is called a laser Doppler anemometer.

Laser Doppler anemometers include the three types shown in Fig. 11.6 and described below.

Reference beam type

When a particle is moving in a fluid at velocity u as shown in Fig. 11.6(a), by measuring the difference in frequency f_D between the reference light and the scattered light observed in the direction of angle 2θ , the flow velocity u can be obtained from the following equation:

$$u = \frac{\lambda f_D}{2 \sin \theta} \quad (11.2)$$

where λ is the wavelength of the laser light.

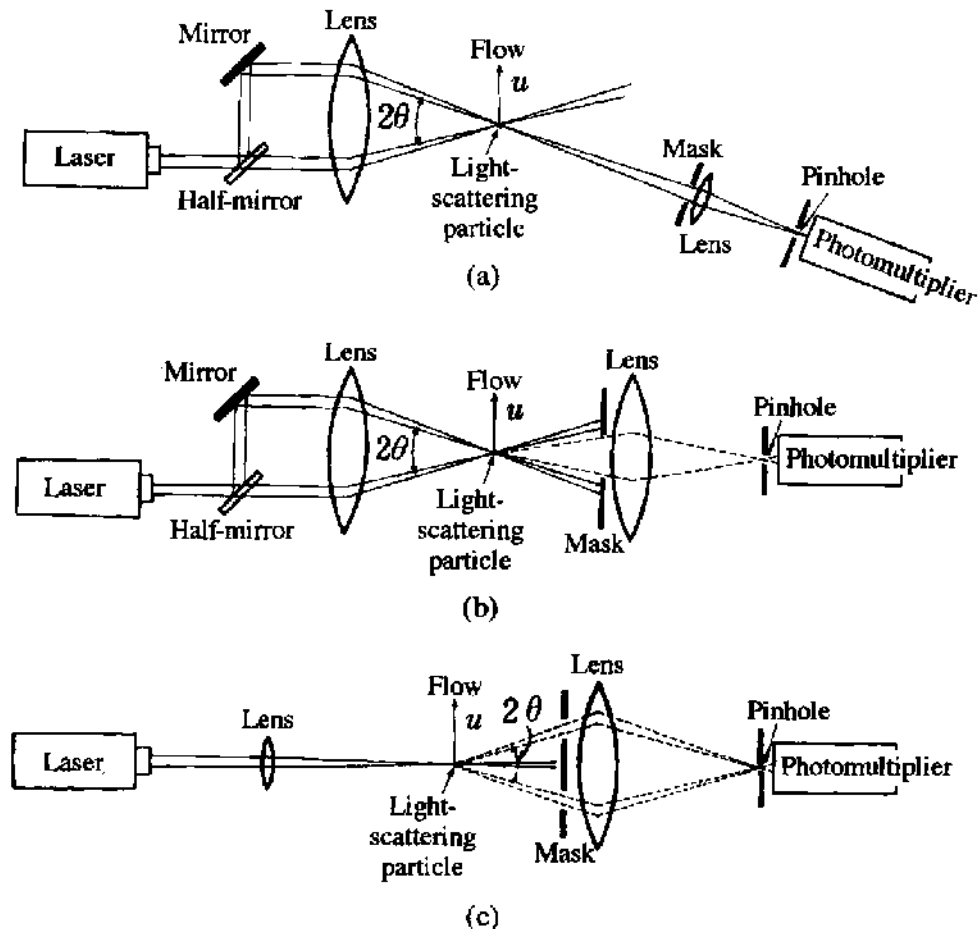

Fig. 11.6 Laser Doppler anemometers: (a) reference beam type; (b) interference fringe type; (c) single-beam type

Interference fringe type

As shown in Fig. 11.6(b), the flow velocity is obtained by using a photomultiplier to detect the alternating light intensity scattered when a particle passes the interference fringes. The velocity is again calculated using eqn (11.2).

Single-beam type

As shown in Fig. 11.6(c), by using the interference of the scattered light in two directions from a single incident beam, the flow velocity can be obtained as for the interference type.

11.2 Measurement of flow discharge

11.2.1 Method using a collecting vessel

This method involves measuring the fluid discharge by collecting it in a vessel and measuring its weight or volume. In the case of a gas, the temperature and pressure of the gas in the vessel are measured allowing conversion to

another volume under standard conditions of temperature and pressure or to mass.

11.2.2 Methods using flow restrictions

Discharge measurement using flow restrictions is widely used in industry. Restrictions include the orifice, nozzle and Venturi tube. The flow rate is obtained by detecting the difference in pressures upstream and downstream of the device. Flow measurement methods are stipulated in British Standards BS1042 (1992).¹

Orifice plate

The construction of an orifice plate is shown in Fig. 11.7. It is set inside a straight pipe. The flow rate is found by measuring the difference in pressures across it. The flow rate is calculated as follows:

$$Q = \alpha \frac{\pi d^2}{4} \sqrt{\frac{2\Delta p}{\rho}} \quad (11.3)$$

where α is called the flow coefficient and Δp is the pressure difference across the orifice plate.

The symbol C was used for the coefficient of discharge in eqn (5.25). For

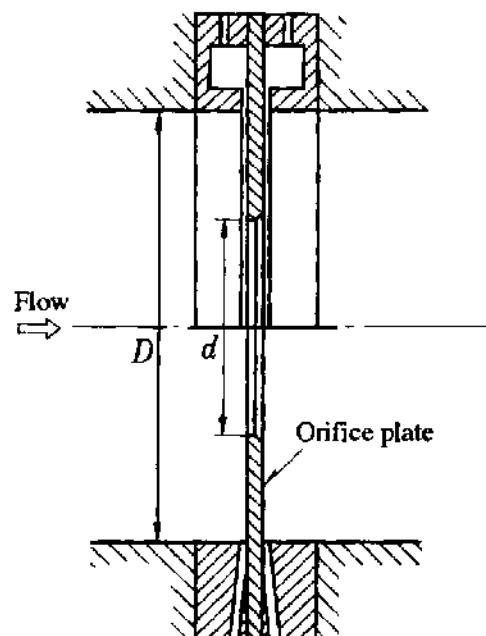

Fig. 11.7 Orifice plate with pressure tapplings (corner and flange)

¹ British Standards BS1042, *Measurement of Fluid Flow in Closed Conduits*, British Standards Institution.

all the above cases, the relationship between flow coefficients α and coefficient of discharge C is

$$C = \alpha/E \quad (11.4)$$

where the approach velocity coefficient $E = (1 - \beta^4)^{-1/2}$ and the throttle diameter ratio $\beta = d/D$.

It can be seen that the effect of the flow velocity in the pipe is to increase the flow rate for the same pressure drop Δp by the factor E , compared with flow from a tank or reservoir as in eqn (5.25).

To obtain the pressure difference either the corner tappings or flange tappings (Fig. 11.7) or pipe tappings are used.

For the case of a gas, an expansion factor is needed as follows:

$$Q_{v1} = \alpha \varepsilon \frac{\pi d^2}{4} \sqrt{\frac{2\Delta p}{\rho_1}} \quad (11.5)$$

$$m = \alpha \varepsilon \frac{\pi d^2}{4} \sqrt{2\rho_1 \Delta p} \quad (11.6)$$

where Q_{v1} is the upstream volume flow rate, m is the mass flow rate, and ρ_1 is the upstream fluid density.

Nozzle

The design of a nozzle is shown in Fig. 11.8, and the measuring method and calculation formula are therefore the same as those for an orifice plate. For a nozzle, the flow loss is smaller than for an orifice, and also the flow coefficient is larger.

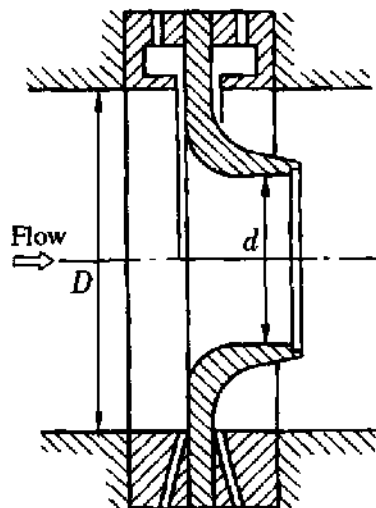

Fig. 11.8 ISA 1932 nozzle

Venturi tube

The principle of the Venturi tube was explained in Section 5.2.2. British Standards provides the standards for both nozzle-type and cone-type Venturi tubes as shown in Fig. 11.9.

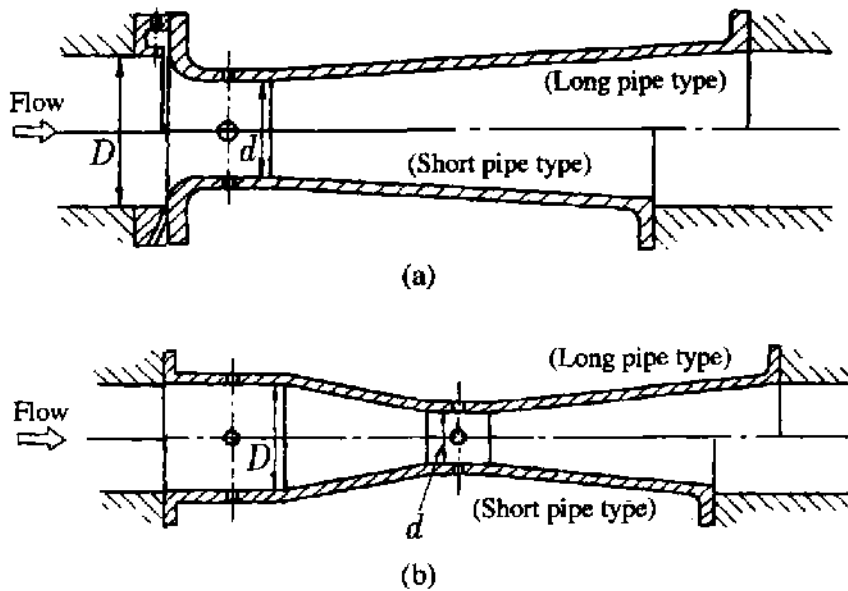

Fig. 11.9 Venturi tubes: (a) nozzle type; (b) cone type

The calculation of the discharge is again the same as that for the orifice plate:

$$Q = \alpha \frac{\pi d^2}{4} \sqrt{\frac{2\Delta p}{\rho}} \quad (11.7)$$

In the case of a gas, as for the orifice plate, eqns (11.4) and (11.5) are used.

11.2.3 Area flowmeter²

The flowmeters explained in Section 11.2.2 indicate the flow from the pressure difference across the restriction. An area flowmeter, however, has a changing level of restriction such that the pressure difference remains constant, and the flow rate is induced by the flow area. Area meters include float, piston and gate types.

A float-type area flowmeter (rotameter) has, as shown in Fig. 11.10, a float which is suspended in a vertical tapered tube. The flow produces a pressure difference across the float. The float rests in a position where the combined forces of pressure drag, frictional drag and buoyancy balance its weight. In this case, ignoring friction, flow Q is expressed by the following equation:

$$Q = C_d a_x \sqrt{\frac{2gV(\rho_f - \rho)}{\rho a_0}} \quad (11.8)$$

where ρ is the fluid density, C_d is the coefficient of discharge, a_x is the area

² British Standard BS7405, (1992).

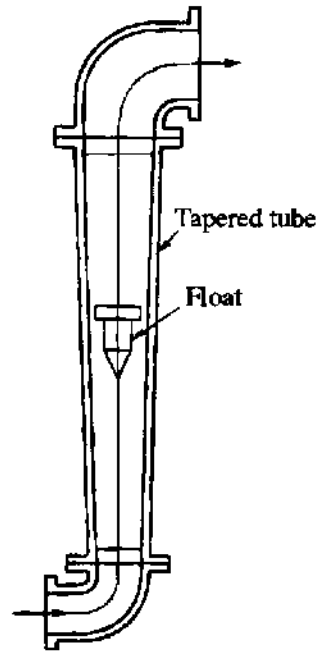

Fig. 11.10 Float-type area flowmeter (Rotameter)

of the annulus through which the fluid passes outside the float, V is the float volume, ρ_f is the float density and a_0 is the maximum section area of the float. Since a_x changes in proportion to the float position, if C_d is constant the equilibrium height of the float in the tube is proportional to the flow.

11.2.4 Positive displacement flowmeter

A positive displacement flowmeter with continuous flow relies on some form of measuring chamber of constant volume. It is then possible to obtain the integrated volume by counting the number of times the volume is filled, and the flow rate by measuring the number of times this is done per second. As a

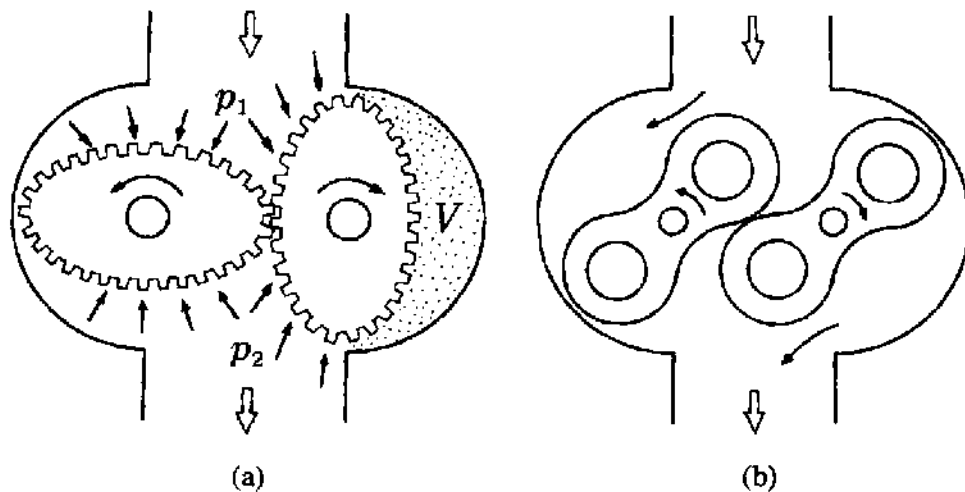

Fig. 11.11 Positive displacement flowmeters: (a) oval gear type; (b) Roots type

typical example, Fig. 11.11 shows oval gear and Roots-type positive displacement meters.

Because of the difference between the flow inlet pressure p_1 and the flow outlet pressure p_2 of fluid, the vertically set gear (Fig. 11.11(a)) turns in the direction of the arrow. Thus, every complete revolution sends out fluid of volume $4V$.

11.2.5 Turbine flowmeter

If a turbine is placed in the course of a flow, the turbine rotates owing to the velocity energy of the fluid. Since they are almost proportional, the flow velocity is obtainable from the rotational velocity of the turbine, while the integrated volume can be calculated by counting the number of revolutions.

The flowmeter has long been used as a water meter. Figure 11.12 shows a turbine meter used industrially for flow rate measurement of various fluids. A pulse is induced every time the blade of the turbine passes the magnetic coil face and the pulse frequency is proportional to the volume flow rate.

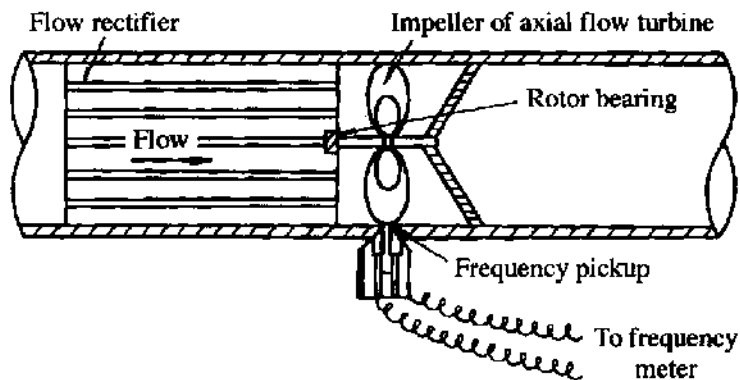

Fig. 11.12 Turbine flowmeter

11.2.6 Magnetic flowmeter

As shown in Fig. 11.13, when a conducting fluid flows in a non-conducting section of a measuring tube to which a magnetic field of flux density B is applied normal to the flow direction, an electromotive force E proportional to the mean flow velocity v is induced in the liquid (Faraday's law of electromagnetic induction) which, after amplification, permits computation of the volume flow rate Q . The electromotive force is detected by inserting two electrodes into the tube in contact with the fluid and normal to both the flow and magnetic field directions. In other words, if the tube diameter is d , then

$$E = Bdv \quad (11.9)$$

and

$$Q = \frac{\pi d E}{4B} \quad (11.10)$$

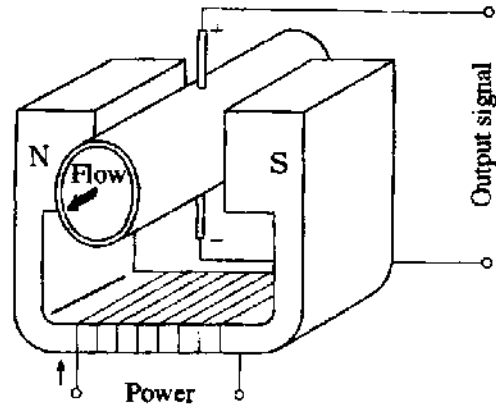

Fig. 11.13 Magnetic flowmeter

Since this flowmeter has no pressure loss, measurement can be made irrespective of the viscosity, specific gravity, pressure and Reynolds number of the fluid.

11.2.7 Ultrasonic flowmeter

As shown in Fig. 11.14, piezocrystals A and B are located a distance l apart on a line passing obliquely through the pipe centre line. Assume that an ultrasonic wave pulse sent from a transmitter at A is received by the detector at B t_1 seconds later. Then, exchanging the functions of A and B by the send-receive switch, an ultrasonic wave pulse sent from B is detected by A t_2 seconds later. Thus

$$t_1 = \frac{l}{a + v \cos \theta} \quad t_2 = \frac{l}{a - v \cos \theta}$$

$$\frac{1}{t_1} - \frac{1}{t_2} = \frac{a + v \cos \theta}{l} - \frac{a - v \cos \theta}{l} = \frac{2v \cos \theta}{l}$$

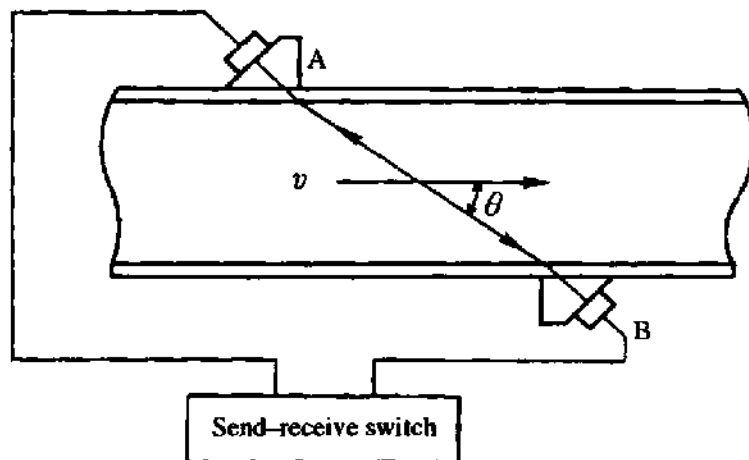

Fig. 11.14 Ultrasonic flowmeter

where a is the sonic velocity in the fluid. From this equation,

$$v = \frac{1}{2 \cos \theta} \left(\frac{1}{t_1} - \frac{1}{t_2} \right) \quad (11.11)$$

This flowmeter has the same merits as an electromagnetic flowmeter and an additional benefit of usability in a non-conducting fluid. On the other hand it has the disadvantages of complex construction and high price.

11.2.8 Vortex shedding flowmeter³

If a cylinder (diameter d) is placed in a flow, Kármán vortices develop behind it. The frequency f of vortex shedding from the cylinder is shown in eqn (9.7). The Strouhal number changes with the Reynolds number, but it is almost constant at 0.2 within the range of $Re = 300-100\,000$. In other words, the flow velocity U is expressed by the following equation:

$$U = fd/0.2 \quad (11.12)$$

One practical configuration, shown in Fig. 11.15, induces fluid movement through the cylinder for electrical detection of the vortices, and thus measurement of the flow rate.

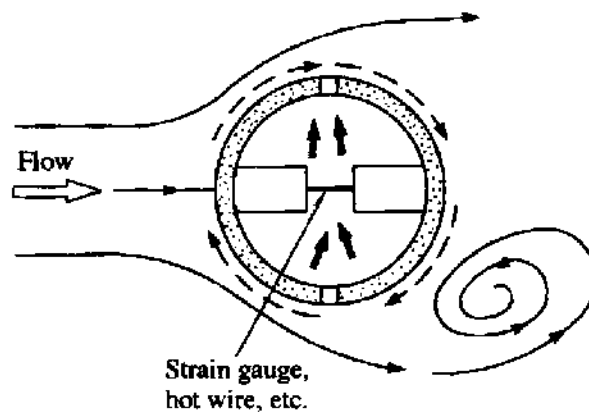

Fig. 11.15 Vortex shedding flowmeter

11.2.9 Fluidic flowmeter

As shown in Fig. 11.16, with an appropriate feedback mechanism a wall attachment amplifier can become a fluidic oscillator whose jet spontaneously oscillates at a frequency proportional to the volume flow rate of the main jet flow. The device can thus be used as a flowmeter.^{4,5}

³ Yamazaki, H. *et al.*, *Journal of Instrumentation and Control*, 10 (1971), 173.

⁴ Boucher, R. F. and Mazharoglu, C., *International Gas Research Conference*, (1987), 522.

⁵ Yamazaki, H. *et al.*, *Proc. FLUCOME'85*, Vol. 2 (1985), 617.

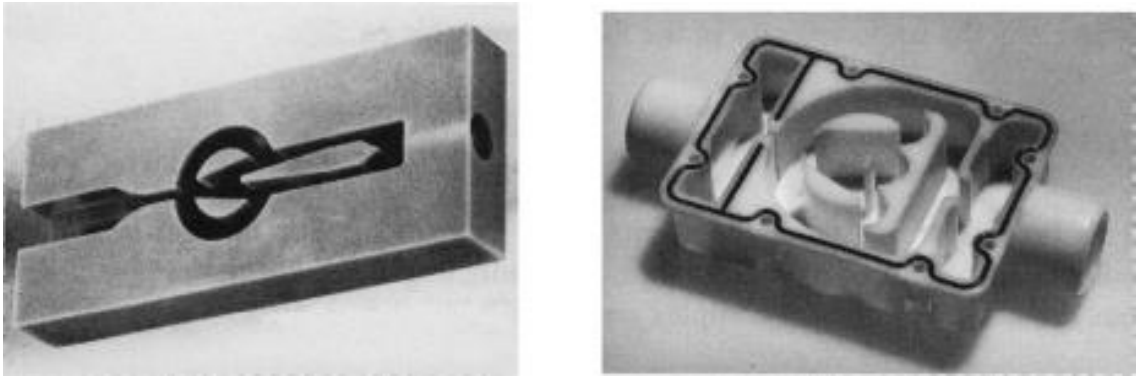

Fig. 11.16 Fluidic flowmeter

11.2.10 Weir⁶

As shown in Fig. 11.17, the three principal weir configurations are classified by shape into triangular, rectangular and full-width weirs.

Table 11.1 shows the flow computation formulae and the applicable scope for such weirs.

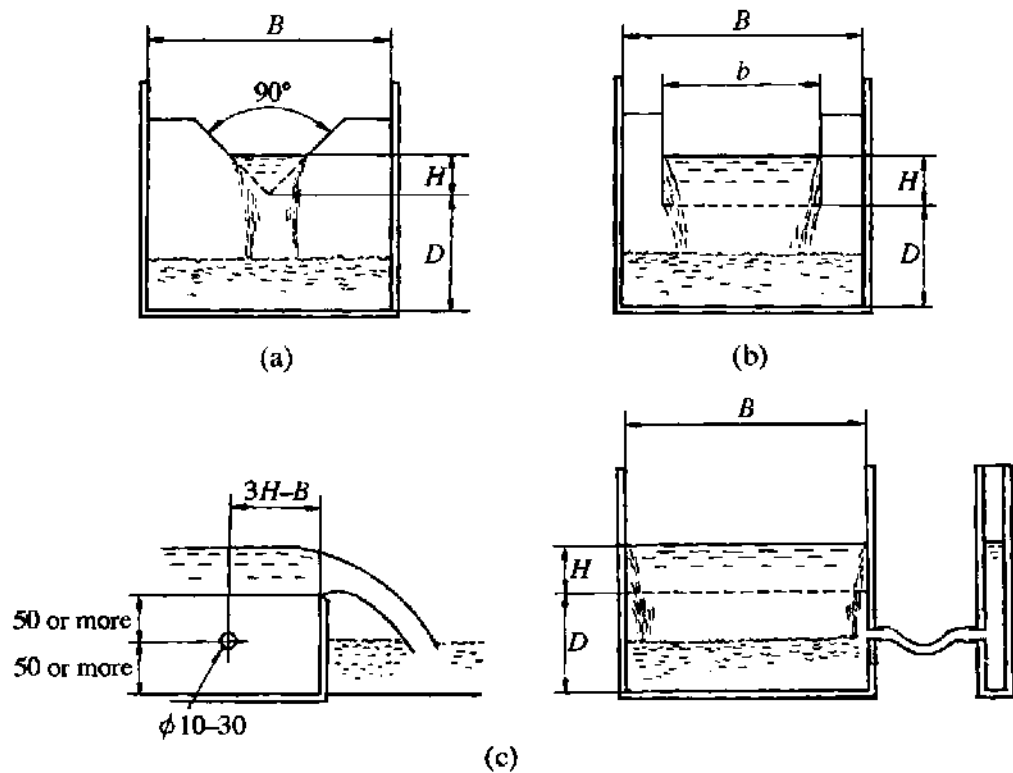

Fig. 11.17 Weirs: (a) triangular; (b) rectangular; (c) full width

⁶ British Standard BS3680.

Table 11.1 Flow computation formulae for weirs in British Standard BS 3680

Kind of weir	Triangular weir	Rectangular weir	Full-width weir
Discharge computation formula	$Q = \frac{8}{15} C \sqrt{2g} H^{3/2} \text{ (m}^3/\text{s)}$ $C = 0.5785$ $H = H + 0.00085$	$Q = C \frac{2}{3} \sqrt{2gb} H^{3/2} \text{ (m}^3/\text{s)}$ $C = \left[0.578 + 0.037 \left(\frac{b}{B} \right)^2 + \frac{0.003615 - 0.0030 \left(\frac{b}{B} \right)^2}{H + 0.0016} \right]$ $\times \left[1 + 0.5 \left(\frac{b}{B} \right)^4 \left(\frac{H}{H+D} \right)^3 \right]$	$Q = C \frac{2}{3} \sqrt{2gb} H^{3/2} \text{ (m}^3/\text{s)}$ $C = 0.596 + 0.091 \frac{H}{D}$ $H = H + 0.001$
Applicable range	$\frac{H}{D} < 0.4$ $\frac{H}{B} < 0.2$ $0.05 \text{ m} < H < 0.38 \text{ m}$ $D > 0.45 \text{ m}$ $B > 1.0 \text{ m}$	$\frac{b}{B} > 0.3$ $\frac{H}{D} < 1.0$ $0.025 \text{ m} < H < 0.80 \text{ m}$ $D > 0.30 \text{ m}$	$\frac{b}{B} = 1.0$ $\frac{H}{D} < 2.5$ $H > 0.03$ $b > 0.20$ $D > 0.10$

11.3 Problems

- The velocity of water flowing in a pipe was measured with a Pitot tube, and the differential pressure read on a connected mercury manometer was 8 cm. Assuming that the velocity coefficient for the Pitot tube is one, obtain the flow velocity. Assume that the water temperature is 20°C and the specific gravity of mercury $s = 13.5$.
- Air flow was measured with the three-hole Pitot tube shown in Fig. 11.18, and it was found that the heights B and C of the water manometer were equal whilst A was 5 cm lower. What was the air flow velocity? Assume that the temperature was 20°C and the air density is 1.205 kg/m³.

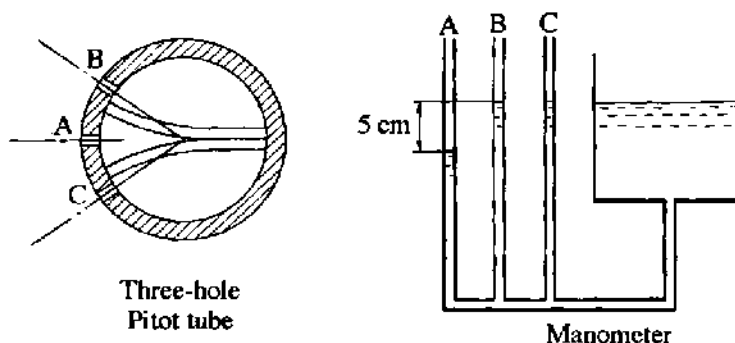

Fig. 11.18

- An orifice of diameter 50 cm on a pipe of diameter 100 mm was used to measure air flow. The differential pressure read on a connected mercury manometer was 120 mm. Assuming that the discharge coefficient $\alpha = 0.62$ and the gas expansion coefficient $\epsilon = 0.98$, obtain the mass flow

rate. Assume that the pressure and temperature upstream of the orifice are 196 kPa and 20°C respectively.

4. A volume of $3.6 \times 10^{-3} \text{ m}^3$ of water per second flows from an orifice of diameter $d = 50 \text{ mm}$ in the side of the water tank shown in Fig. 11.19. The minimum section diameter of the jet flow is $d' = 40 \text{ mm}$. Obtain the contraction coefficient C_c , velocity coefficient C_v and discharge coefficient C of this orifice.

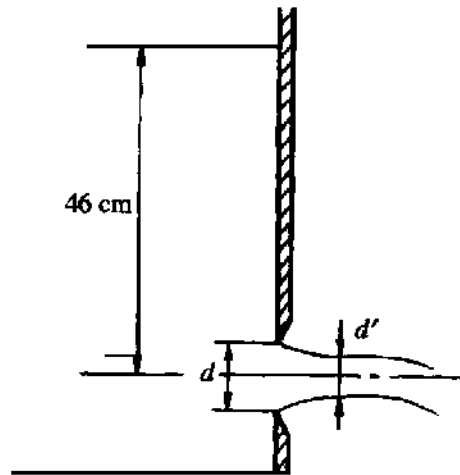

Fig. 11.19

5. A pipe line contains both an orifice and a nozzle. When $Re = 1 \times 10^5$, and with a throttle diameter ratio $\beta = 0.6$ for both, the flow coefficient α is 0.65 for the orifice but 1.03 for the nozzle. Explain why.
6. Explain the principle of a hot-wire flow anemometer. Over what points should caution be especially exercised?
7. Explain the principles and features of the laser Doppler anemometer.
8. With a vortex-shedding flowmeter, cylinder diameter 2 cm, the shedding frequency was measured as 5 Hz. What was the flow velocity?
9. Obtain the flow formulae for a rectangular weir and a triangular weir.
10. Assuming a reading error of 2% for both rectangular and triangular weirs, what are the resulting percentage flow errors?